

TLB Series

▶ TLB-CON5-FIO Pulsating light amplifier

- 100%-check of objects (tolerance range checking)
- Object positioning and thickness control (in μm -range)
- High trigger accuracy (in μm -range)
- High switching frequency (typ. 25 kHz)
- Parameterizable under Windows®
- Threshold correction can be activated
- Trigger threshold, tolerance range adjustable under Windows®
- Output polarity reversible under Windows®
- Dirt accumulation compensated evaluation
- Fiber optics connector (for connection of fiber optics of FIO Series)



Design

Product name:

TLB-CON5-FIO

incl. Windows® PC software FLB/TLB-Scope

Please order optical fibers separately
(cf. catalog FIO Series)

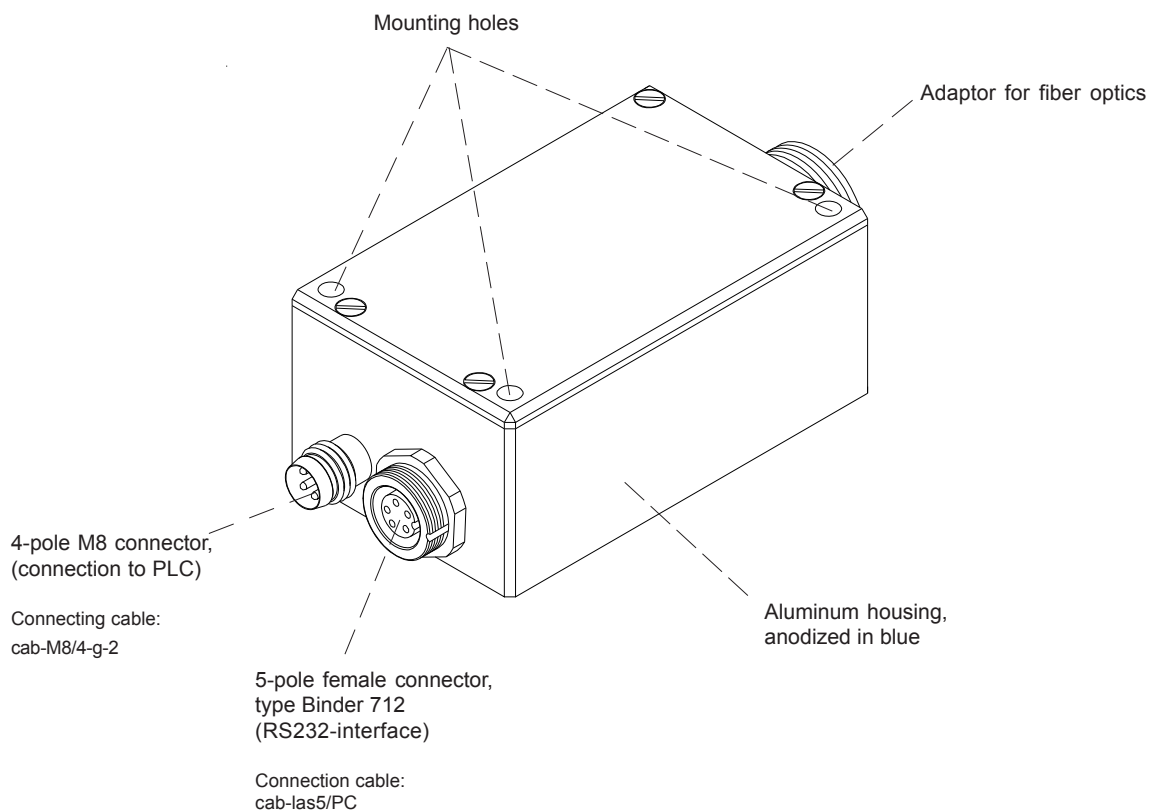



Technical Data

Model	TLB-CON5-FIO
Light source	IR diode (905 nm)
Voltage supply	+24VDC ± 10%, reversed polarity protection, overload protection
Current consumption	max. 150 mA
Minimum detectable object	< 10 µm (depends on the optical fiber used)
Resolution	depends on the optical fiber used
Operating temperature range	-20°C ... +60°C
Storage temperature range	-20°C ... +85°C
Mechanical protection	IP64
Threshold correction	Can be activated via PC
Output ANALOG	0V ... +10V
Output DIGITAL	Adjustable via PC: Q: npn dark-switching (npn normally open) / pnp bright-switching (pnp normally closed) Qinv: npn bright-switching (npn normally closed) / pnp dark-switching (pnp normally open)
Current control input (I-Control)	Transmitting power adjustable via PC
Switching state indication	Visualization by means of an LED
Connector type	Connection to PLC: 4-pole M8-connector Connection to PC: 5-pole flange socket, type Binder 712 Connection to optical fiber via adaptor
Dynamic switching output (pulse lengthening)	Can be activated via PC (0 ms ... 200 ms)
Switching frequency	Approx. 6 kHz
Maximum switching current	100 mA, short circuit protection
Band width analog signal	1 kHz (-3 dB)
Sampling frequency	Typ. 25 kHz
Interface	RS232, parameterizable under Windows®
Housing	Aluminum, anodized in blue
Housing dimensions	Approx. 65 mm x 40 mm x 29 mm (without connector)
EMC test acc. to	DIN EN 60947-5-2
Averaging	Can be activated via PC
Tolerance range / threshold	Can be activated via PC

Dimensions

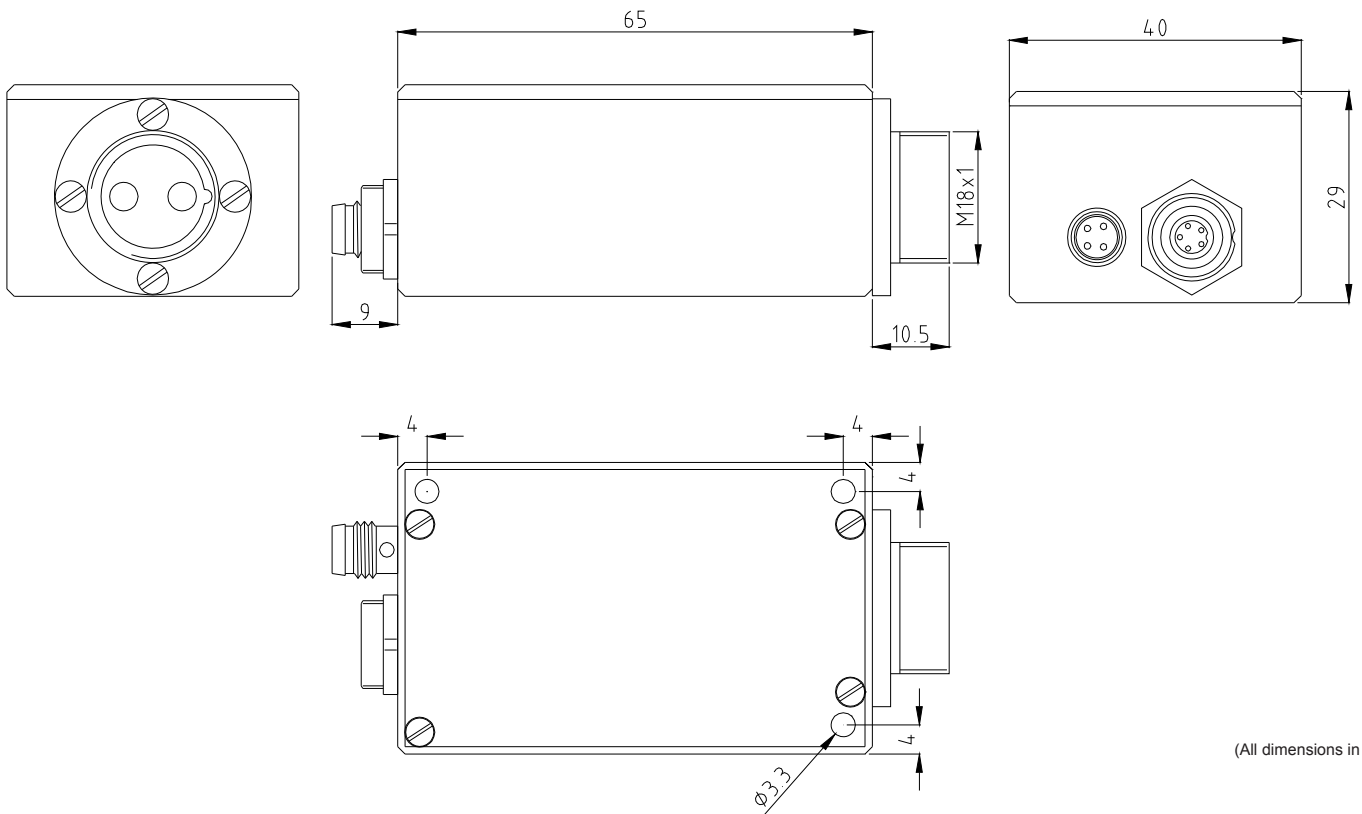

Connector Assignment

4-pin M8-connector

Pin-No.:	(Color)	Assignment
1	(brn)	+Ub (+24VDC ± 10%)
2	(wht)	ANALOG (0V...+10V)
3	(blu)	GND (0V)
4	(blk)	DIGITAL OUT

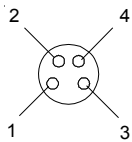

Connecting cable to PLC:
cab-M8/4-g-2

5-pin female connector, type Binder 712

Pin-No.:	Assignment:
1	GND (0V)
2	TX0
3	RX0
4	n.c.
5	n.c.

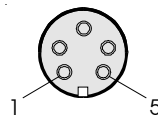

Connecting cable to PC:
cab-las5/PC



FLB/TLB Scope Windows® software:

The TLB-CON5 control unit can be easily parameterized with the help of the Windows® user interface. For this purpose the TLB-CON5 control unit is connected to the PC by way of the cab-las5/PC interface cable. When parameterization is finished, the PC can be disconnected again.

Windows® user interface:

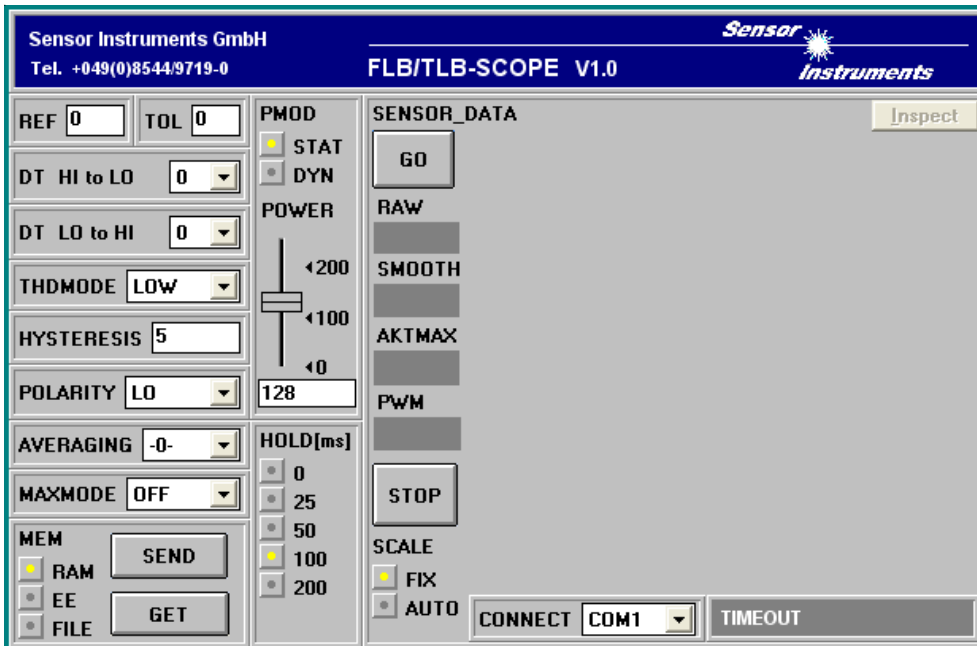

Display of the current measurement data in numerical and graphical form:

Activation of the measurement data field (serves as a setting aid in static operation). The measurement data are displayed in "digits" with an 8-bit resolution of the measurement range. The operating measurement range (aperture) is displayed in the range from 0 to 255. The resolution is: Aperture size / 256.

Display of the raw data

Display of the averaged value

Display of the current maximum value

Display of the laser power

Interruption of measurement data transfer

Tolerance band display

Current measurement signal

Tolerance band display

Parameterisation

Among others, the following parameters can be set via software FLT/TLB-Scope:

REF 128

REF:

After a mouse-click on this edit-box the reference value can be specified here by entering a numerical value. The reference value corresponds with the teach-in value (setpoint value) of the degree of covering at the light measuring section caused by the target. Because of the 8-bit analog/digital converter the dynamic range is 0 ... 255 A/D units, which is proportional to the respective covering (analog signal 0 ... 10V) at the light measuring section of the sensor.

TOL 20

TOL:

With this edit box a tolerance band can be applied around the currently specified reference value (setpoint value). If the set tolerance limit is exceeded, this leads to a change of switching state at pin 4 (blk) of the 4-pole M8-plug (digital output DIGITAL OUT).

DT HI to LO 4

DT LO to HI 12

DT HI to LO or DT LO to HI:

In this function field a time constant DT for the speed of automatic threshold correction can be set. The current maximum value is cyclically checked by the µC software. The numerical value specified here determines the time interval between two maximum value scans. If the current maximum-value decreases (HI to LO or LO to HI), the current monitoring threshold is automatically corrected with the set delay DT.

Value range: 0 ... 15

Value 0: Minimum time delay, fastest correction.

Value 15: Maximum time delay, slowest correction.

THDMODE HI

THDMODE:

In this function field one of three possible positions of the monitoring thresholds with respect to the reference can be selected.

LOW:

The monitoring threshold (green line) lies below the current reference value. If the current measured value (red graph) falls below this threshold, the digital error output DIGITAL OUT is activated.

HI:

The monitoring threshold (green line) lies above the current reference value. If the current measured value (red graph) rises above this threshold, the digital error output DIGITAL OUT is activated.

WIN:

The monitoring thresholds (green lines) form a symmetric tolerance band around the current reference value. If the current measured value (red graph) violates this tolerance band, the digital error output DIGITAL OUT is activated.

POLARITY LO

POLARITY:

Determines the polarity change of digital output DIGITAL OUT in case of exceeding of a tolerance threshold.

LO := with error DIGITAL OUT = 0VDC (Low-active)

HI := with error DIGITAL OUT = +24VDC (High-active)

AVERAGING -4-

AVERAGING:

Determines the number N of measured values (raw data) over which the sensor signal arriving at the receiver is averaged.

MAXMODE ON

MAXMODE:

With this function field automatic correction of the monitoring thresholds can be switched on and off.

ON:

Automatic threshold correction is active. The current maximum value is checked cyclically.

If the current maximum value decreases, e.g. due to increasing dirt accumulation, the set monitoring thresholds are automatically corrected accordingly.

OFF:

Automatic threshold correction is deactivated.

MEM

RAM SEND

EE GET

FILE

MEM :

This group of function buttons is used for exchanging parameters between the PC and the electronic control unit through the serial RS232 interface.

Parameterisation

HYSTERESIS 5

HYSTERESIS:

The hysteresis setting value applies an additional switching threshold around the currently set tolerance threshold. The switching hysteresis has an effect on the output DIGITAL OUT. It increases the signal stability at the digital output of the electronic control unit.

The illustration below demonstrates the effect of HYSTERESIS presetting:

REF: 120
 TOL: 40
 HYSTERESIS: 15
 POLARITY: HI
 THDMODE: LOW

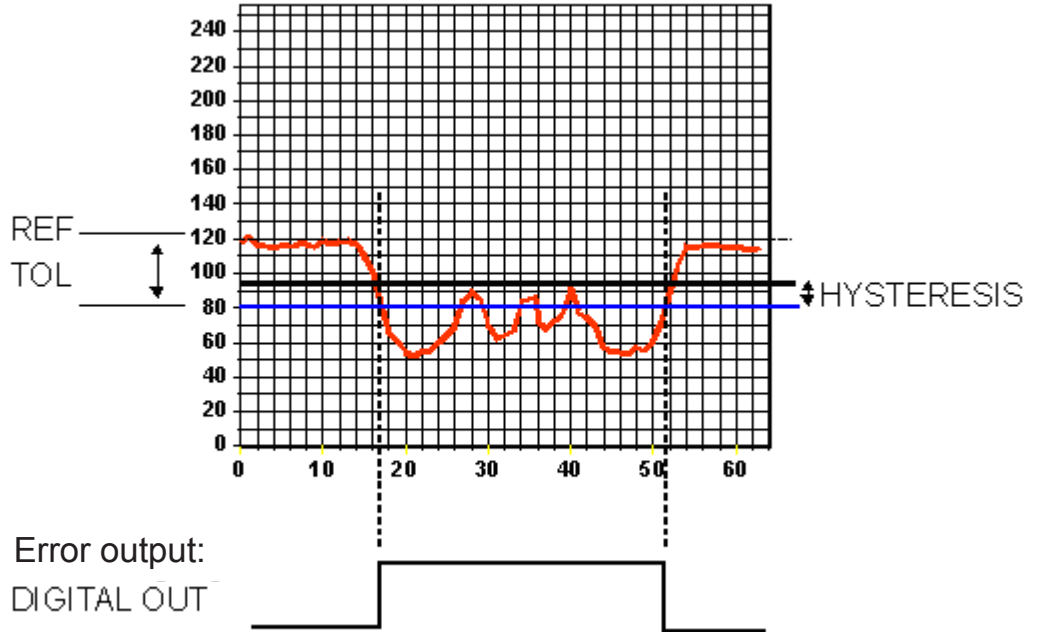

PMOD

STAT
 DYN

POWER

◀ 200
 100
 0

128

PMOD:

In this function group the laser operating mode and the transmitting power at the electronic control unit can be adjusted.

STAT:

With this selection button the transmitting power is constantly kept at the value that is set at the slider.

DYN:

The transmitting power is automatically and dynamically adjusted by means of radiation reflected to the receiver. By way of dynamic adaptation of the transmitting power the µC software tries to keep the current maximum value detected at the receiver in the range 100 to 200 A/D values. In this operation mode the POWER slider has no effect.

POWER:

With this slider the transmitting power is adjusted to a fixed value between 0 and 255 in STAT mode. Any change only becomes effective after the SEND button is pressed.

HOLD[ms]

0
 25
 50
 100
 200

HOLD :

The electronic control unit operates with minimum scan times in the range of 100µs. For this reason most of the SPCs that are connected to the digital error output DIGITAL OUT have difficulties with the safe detection of the resulting short changes of switching states.

By activating the respective HOLD selection button a pulse lengthening at the digital output of the electronic control unit of up to 200 ms can be set.

RAW
130

SMOOTH
128

AKTMAX
125

PWM
64

NUMERICAL VALUE OUTPUT FIELDS:

RAW:

Display of the current measured value (raw data) from the receiver.

SMOOTH:

Display of the current average value over the last N measured values. The value N of the measured value to be averaged is specified in the AVERAGING function field.

AKTMAX:

Display of the current maximum value.

PWM:

Display of the current transmitting power in DYN mode. The transmitting power is adjusted by way of pulse width modulation PWM.

SCALE

FIX
 AUTO

SCALE:

These selection buttons are used for setting the scaling type of the y-axis.

FIX:

Fixed y-axis scaling (value range 0 ... 255 - resulting from 8-bit A/D conversion)

AUTO:

Automatic adaption of y-axis scaling to the current measured values (zoom function).

Parameterisation

FLB/TLB-Scope as an aid for sensor adjustment

Prior to the use of the software aids (graphic display of the sensor signal) the sensor must be manually adjusted to the respective target as accurately as possible. Fine adjustment of the sensor is facilitated by the graphic display of the analog signal (raw signal from the receiver diode - red graph). For this purpose measurement data transfer from the electronic control unit to the PC must first be activated by clicking on the GO button.



GO:
Activation of measurement data transfer through the serial interface. The current raw data are shown in scroll mode in the graphic display window (red graph, the latest value comes from the right side)

PMOD

STAT
 DYN

POWER

◀ 200
◀ 100
◀ 0

128

The raw signal (red graph) from the receiver diode of the sensor should now appear in "scroll mode" in the graphic display window. If this is not so (signal at the upper limit = 255, or at the lower limit = 0), the transmitting power must first be set correctly.
For this purpose the laser mode must be set to STAT (static), and the transmitting power must then be adjusted with the POWER slider until the raw signal (red) lies in the upper third of the measuring range (0 ... 255 8-bit A/D converter).

The transmitting power should be adjusted such that the receiver of the sensor is not in saturation (A/D value >240).

The aim of fine adjustment and transmitting power setting is to achieve a raw signal value in the upper third of the dynamic range in the uncovered situation of the light measuring section ("sensor free").

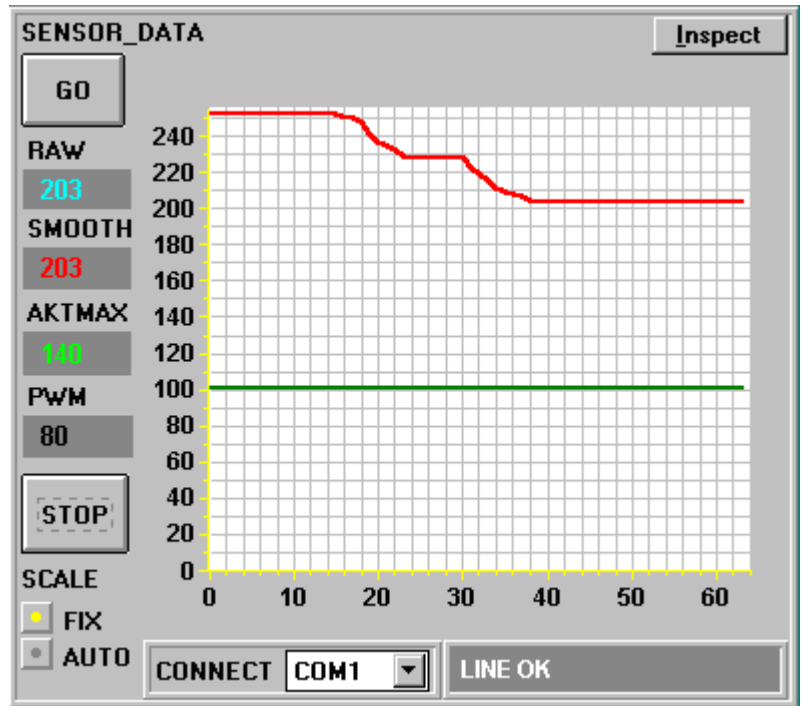

FLB/TLB-Scope as an aid for threshold setting

Threshold mode THDMODE HI:

In this mode the monitoring threshold lies above the current reference value. The distance of the TOL threshold from the reference value REF is determined by the TOL presetting value. In THDMODE HI the hysteresis range lies below the TOL threshold.
If automatic threshold correction is active (MAXMODE=ON), the time constants for threshold correction must be chosen appropriately:

DT LO to HI 12

A high value must be chosen for the DT LO to HI time constant (slow correction). Slow threshold correction prevents the threshold from "moving along" in case of slow exiting of the target from the laser beam.

DT HI to LO 4

A low value must be chosen for the DT HI to LOW time constant (fast correction). After entering of the target into the laser beam the TOL threshold is brought to the reference value again.

For example the target (reference part, accept part) is placed in the light measuring section of the sensor in such a way that the covering by the target results in a raw signal value at the receiver of approx. 120 A/D units (light measuring section covered half). This value of covering is declared as the reference value, in this case e.g. REF=120.

If a target is now brought into the light measuring section, the outer dimension of which increasingly sets the light measuring section free, a monitoring threshold can be preset that can be used for checking the permissible outer dimension of the targets.

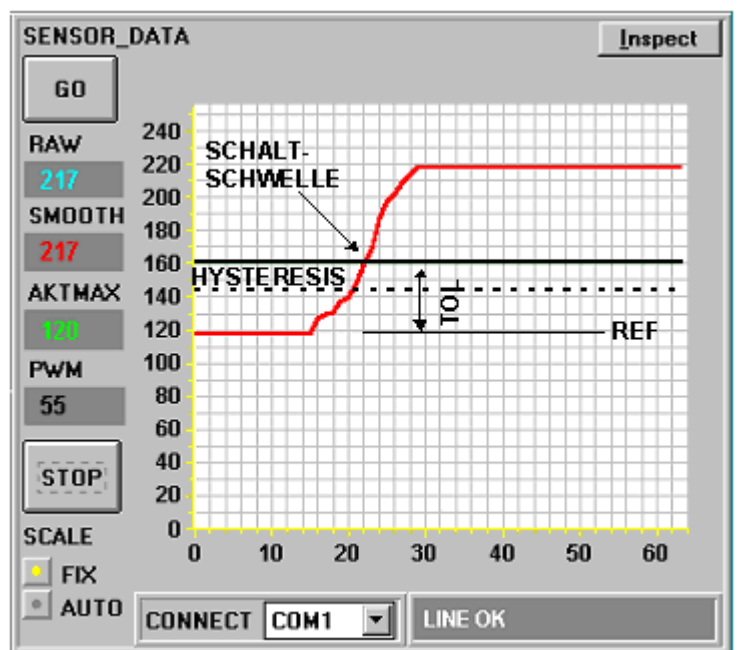

Parameterisation

FLB/TLB-Scope as an aid for threshold setting

Threshold mode THDMODE LOW:

In this mode the monitoring threshold lies below the current reference value. The distance of the monitoring threshold from the reference value REF is determined by the TOL presetting value. In this mode the hysteresis range lies above the TOL threshold. If automatic threshold correction is active (MAXMODE=ON), the time constants for threshold correction must be chosen appropriately:

DT LO to HI 2

A low value must be chosen for the DT LO to HI time constant (fast correction). After passage of the target through the laser beam the TOL threshold quickly is brought to the reference value again.

DT HI to LO 10

A high value must be chosen for the DT HI to LO time constant (slow correction). Slow threshold correction prevents the threshold from "moving along" in case of slow entering of the target into the laser beam.

For example the target is placed in the light measuring section of the sensor in such a way that the covering by the target results in a raw signal value of approx. 170 A/D units at the receiver (light measuring section covered 2/3). This value of covering is declared as the reference value (setpoint value), in this case e.g. REF=170. The decrease of the signal intensity (red graph in the graphic display window) is caused by the increasing covering of the light measuring section due to the movement of the target into the laser beam.

For example this may happen because of a faulty arget, the outer dimensions of which are larger compared to the reference object.

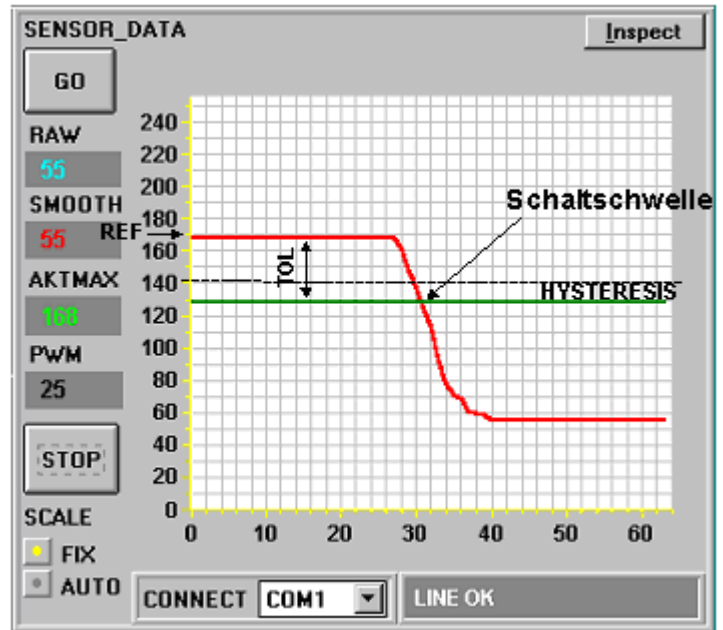

Threshold mode THDMODE WIN:

This mode operates with two monitoring thresholds that lie symmetrically around the current reference value REF. The distance of the monitoring thresholds from the reference value REF is determined by the TOL presetting value. In this mode the two hysteresis ranges lie within the tolerance band. If automatic threshold correction is active (MAXMODE=ON), the time constants for threshold correction must be chosen appropriately:

DT LO to HI 10

A high value must be set for the DT LO to HI time constant (slow correction). Slow threshold correction prevents the upper threshold from "moving along" in case of slow entry of the target into the light measuring section.

DT HI to LO 10

A high value must be chosen for the DT HI to LOW time constant (slow correction). Slow threshold correction prevents the lower threshold from "moving along" in case of slow entry of the target into the light measuring section.

The target (reference object, accept part) is placed in the light measuring section in such a way that the light measuring section is covered half (reference value REF=128). The intensity detected at the receiver of the sensor is proportional to the covering at the light measuring section. A tolerance band of width +/- TOL is applied symmetrically around this reference value.

The picture on the left shows the signal characteristics of an accept part (OK) and of a reject part (NOK). The faulty target (NOK) is detected when the tolerance band is exceeded (change of switching state at the DIGITAL OUT output).

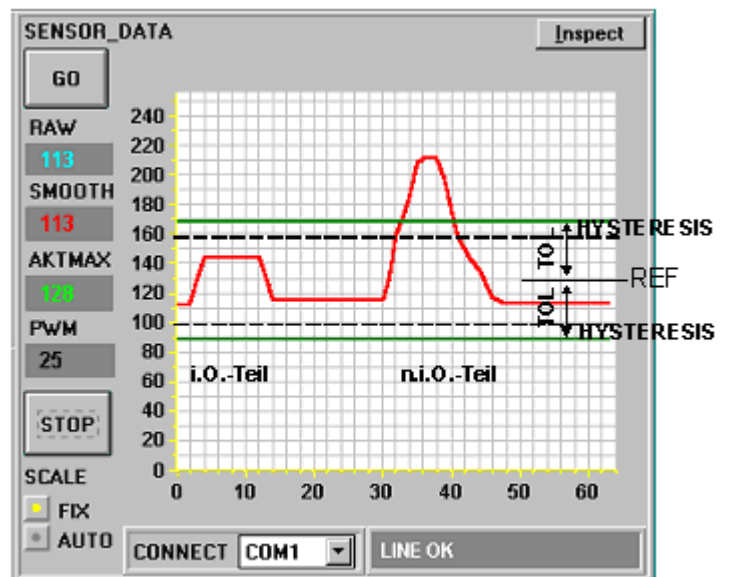



Product Line

Pulsating light amplifiers:

Connecting cables:
cab-M8/4-g-2 (2m)
cab-las5/PC (2m)

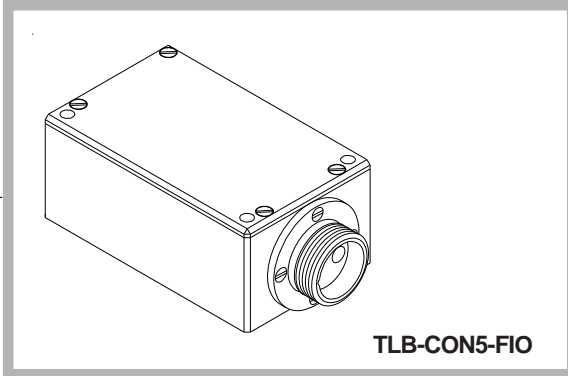

Connecting cable:
cab-las8/702-fem (2m)

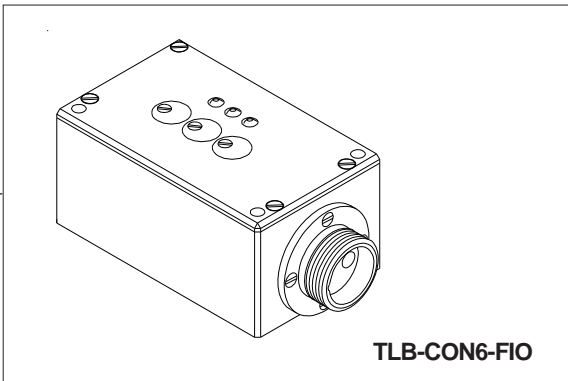

Constant light amplifiers:

Connecting cable:
cab-las8/702-fem (2m)

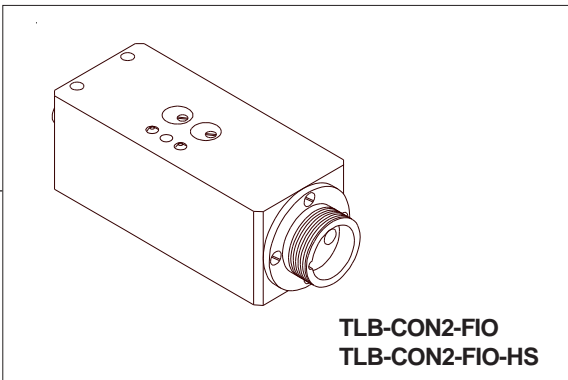

Connecting cable:
cab-las8/702-fem (2m)

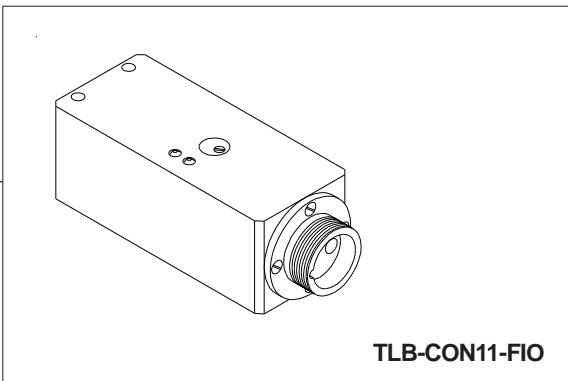

FIO Series
(Fiber optics and
optical frontends)