

# SPECTRO-1 Series

## ► SPECTRO-1-FIO-UV/BL

- Working range: typ. 1 mm ... 100 mm (depends on the fiber optics used and attachment optics)
- Various UV light fiber optics and attachment optics available
- UV LED, 365 nm (AC-/DC-operation or OFF for luminous objects can be switched)
- Detection of luminescent objects
- Optical long-pass filter with cut-off wavelength 450 nm
- High scan frequency
- Gray scale detection (12-bit resolution)
- Insensitive to outside light (in AC-operation)
- Brightness correction can be activated (STAT/DYN)
- Averaging can be activated (from 1 up to over 32000 values)
- TEACH via PC or PLC
- 2 digital inputs (0V/+Ub)
- 2 digital outputs (max. 60 kHz switching frequency)
- 1 analog output (0V...+10V or 4...20mA), selectable via software
- Switching state indication by means of 2 yellow LEDs
- RS232 interface (USB or ETHERNET converter available)
- Parameterizable via Windows® software, scope function
- Temperature compensated (from 0°C to 60°C)
- Automatic threshold correction can be activated
- Various switching threshold functions (window, upper/lower threshold)
- Integrated cooling device for protection against overheating of the sensor



### Design

#### Product name:

#### SPECTRO-1-FIO-UV/BL

(incl. Windows® PC software SPECTRO1-Scope)

#### UV/BL:

The transmitter operates in the ultraviolet range, whereas the receiver is sensitive from the blue range as of a wavelength of 450 nm. This sensor type in reflective or transmitted light operation (by using an appropriate fiber optics) therefore is suitable for the detection of fluorescent objects which by way of UV excitation can be caused to emit light.

**Accessories:** (cf. p. 8-10)

#### UV fiber optics Attachment optics

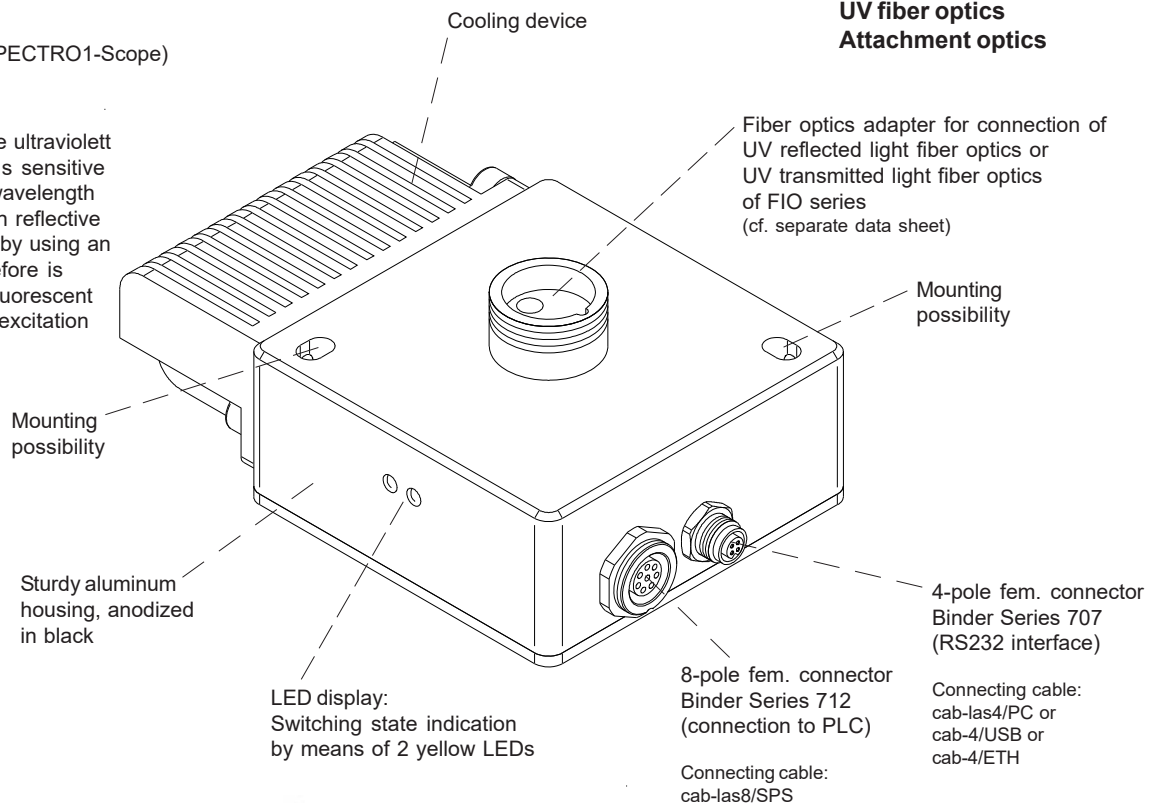



**Technical Data**

Model	SPECTRO-1-FIO-UV/BL		
Voltage supply	+24VDC (± 10%), reverse polarity protected, overcurrent protected		
Current consumption	< 220 mA		
Max. switching current	100 mA, short circuit proof		
Switching state indication	2 yellow LED visualize the physical state of the outputs OUT0 and OUT1		
Digital inputs (2x)	IN0 and IN1 (Pin 3 and 4): digital (0V/+24V)		
Digital outputs (2x)	OUT0 and OUT1 (Pin 5 and 6): digital (0V/+24V), npn-/pnp-able (bright-/dark-switching, can be switched)		
Analog output (1x)	ANALOG (Pin 8): voltage 0 ... +10V or current 4 ... 20mA, adjustable via PC software		
Interface	RS232		
Pulse lengthening	0 ... 100 ms, adjustable via PC software		
Averaging	max. 32768 values, adjustable via PC software		
Scan frequency (LED mode AC, DC or OFF, can be switched via PC software)	LED mode AC (depends on parameterization):		LED mode DC / OFF (depends on parameterization):
	Frequency [Hz]	Digital outputs	Analog output
	Max. 50 000	Off	Off
	Max. 48 000	On	Off
	Max. 42 000	Off	On
Max. 41 000	On	On	On
	Measurements were made with the smallest gain at the receiver (AMP1). At the highest gain (AMP8), the frequency is reduced by a factor of 10.		The frequency is independent of the gain set at the receiver.
Switching frequency	max. 60 kHz		
Analog band width	max. 90 kHz (-3 dB)		
Transmitter (light source)	UV LED, 365 nm		
Transmitter control	can be switched via PC software: AC operation (LED MODE-AC), DC operation (LED MODE-DC), OFF operation (LED MODE-OFF)		
Object distance (measuring range)	with reflected light fiber optics: typ. 1 mm ... 100 mm (depends on fiber optics and attachment optics)		
Receiver	photo diode		
Optical filter	long-pass filter with cut-off wavelength 450 nm		
Receiver gain setting	8 steps (AMP1 ... AMP8), adjustable via PC software		
Ambient light	max. 5000 Lux		
Size of light spot	typ. Ø 1 mm ... Ø 10 mm depends on fiber optics and attachment optics used (cf. catalog FIO series)		
Reproducibility	2 digits at 12-bit A/D conversion		
Housing dimensions	LxWxH approx. 95 mm x 65 mm x 38 mm (incl. fiber optics adaptor M18x1, without connectors)		
Housing material	aluminum, anodized in black		
Enclosure rating	IP64		
Connecting cables	to PLC: cab-las8/SPS or cab-las8/SPS-w to PC/RS232 interface: cab-las4/PC or cab-las4/PC-w to PC/USB interface: cab-4/USB or cab-4/USB-w to PC/Ethernet interface: cab-4/ETH		
Type of connector	connection to PLC: 8-pole fem. connector (Binder series 712) connection to PC: 4-pole fem. connector (Binder series 707)		
Operating temp. range	-20°C ... +55°C		
Storage temperature range	-20°C ... +85°C		
EMC test acc. to	DIN EN 60947-5-2		

Dimensions

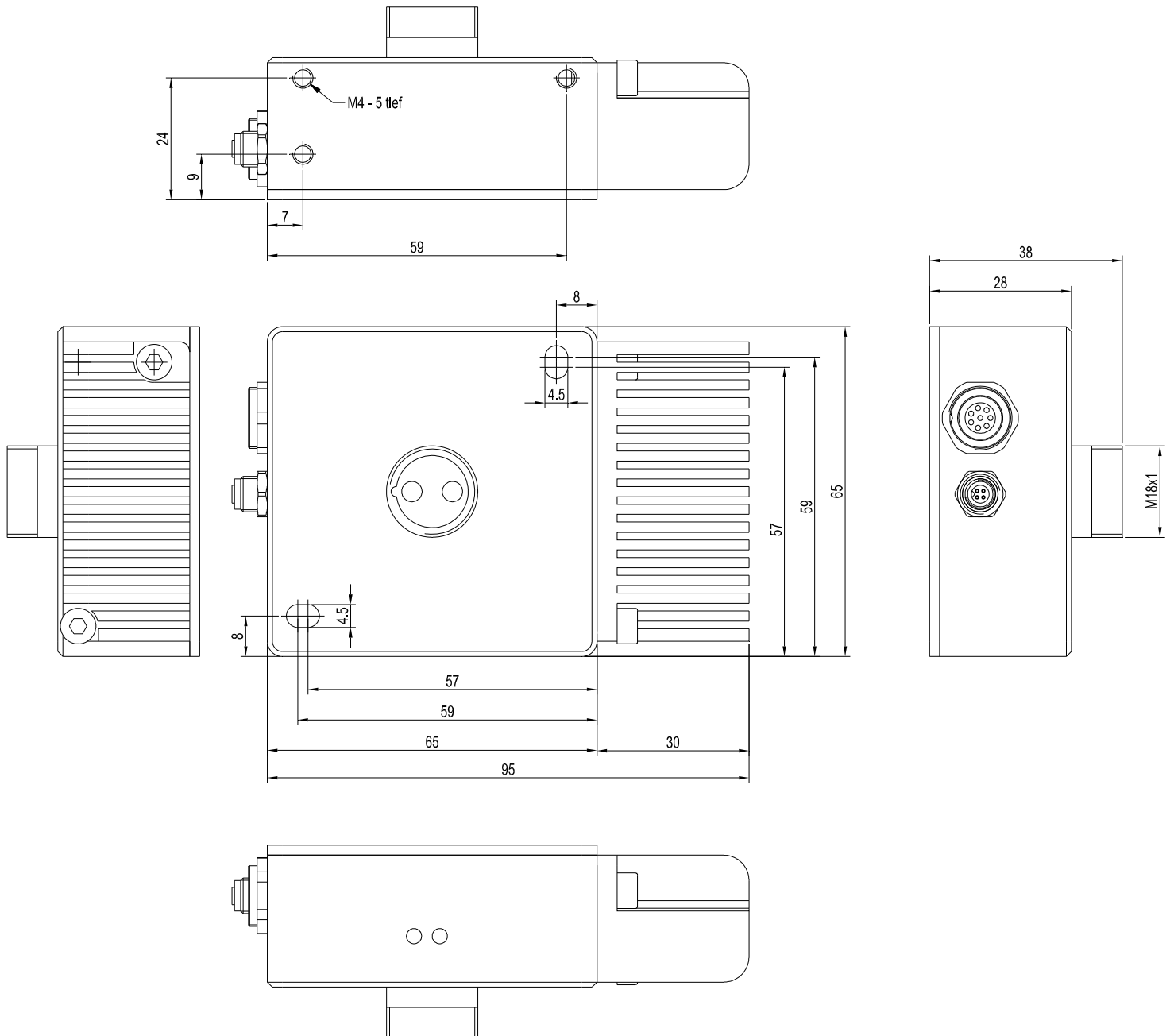

All dimensions in mm



**Connector Assignment**
**Connection to PLC:****8-pole fem. connector Binder series 712**

Pin:	Color:	Assignment:
1	white	GND (0V)
2	brown	+24VDC ( $\pm 10\%$ )
3	green	IN0 (Digital 0: 0 ... 1V, Digital 1: +Ub - 10%)
4	yellow	IN1 (Digital 0: 0 ... 1V, Digital 1: +Ub - 10%)
5	grey	OUT0 (Digital 0: Type 0 ... 1V, Digital 1: Type +Ub - 10%)
6	pink or black	OUT1 (Digital 0: Type 0 ... 1V, Digital 1: Type +Ub - 10%)
7	blue	not connected
8	red	ANALOG (voltage 0...+10V or current 4...20mA)

**Connecting cable:**

cab-las8/SPS-(length)

cab-las8/SPS-w-(length) (angle type 90°)

(standard length 2m)

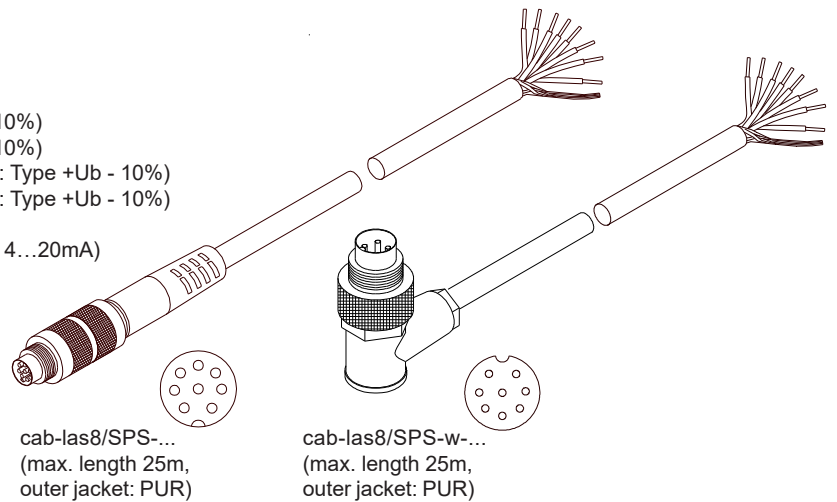
cab-las8/SPS-...  
(max. length 25m,  
outer jacket: PUR)cab-las8/SPS-w-...  
(max. length 25m,  
outer jacket: PUR)**Connection to PC:****4-pole fem. connector Binder Series 707**

Pin:	Assignment:
1	+24VDC (+Ub, OUT)
2	GND (0V)
3	RxD
4	TxD

**Connection via RS232 interface at the PC:****Connecting cable:**

cab-las4/PC-(length)

cab-las4/PC-w-(length) (angle type 90°)

(standard length 2m)

**alternative:****Connection via USB interface at the PC:****USB converter (incl. driver software):**

cab-4/USB-(length)

cab-4/USB-w-(length) (angle type 90°)

(standard length 2m)

**alternative:****Connection to local network via Ethernet bus:****Ethernet converter (incl. software „SensorFinder“):**

cab-4/ETH-500

(standard length 0.5m)

**Optional: External CAT5 cable, e.g.**

cab-eth/M12D-RJ45-flx-(length)

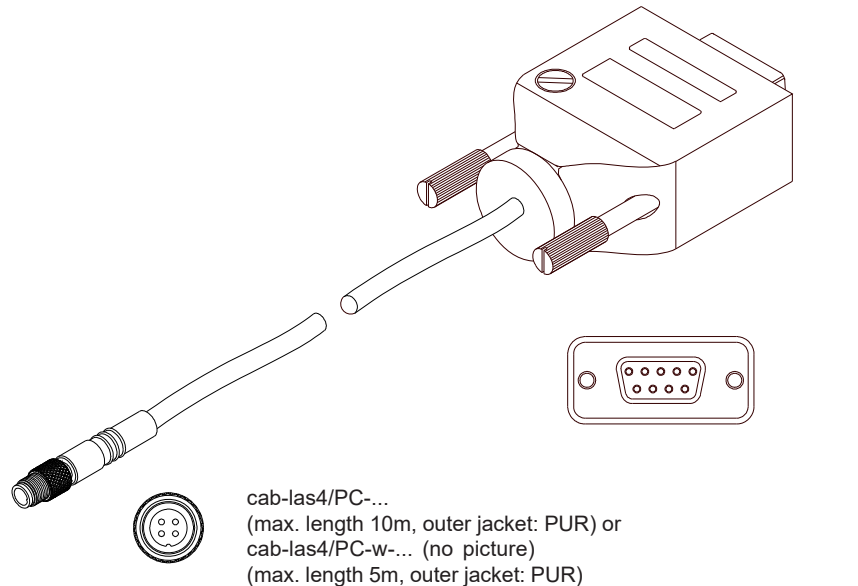
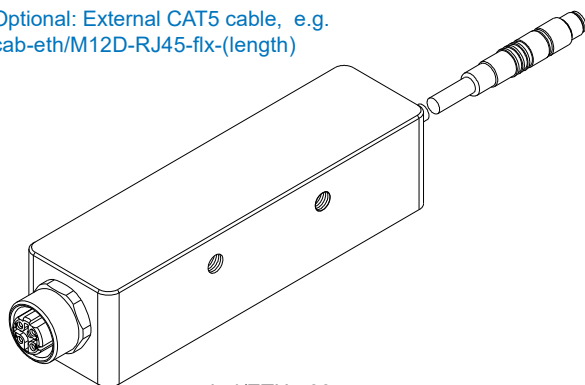
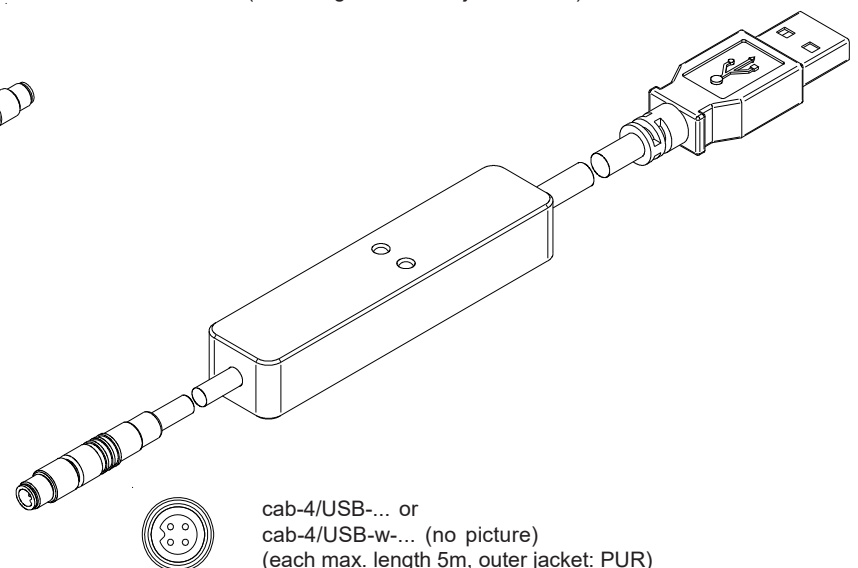
cab-las4/PC-...  
(max. length 10m, outer jacket: PUR) or  
cab-las4/PC-w-... (no picture)  
(max. length 5m, outer jacket: PUR)cab-4/ETH-500  
(length 0.5m, outer jacket: PUR)  
4-pole M12 fem. conn. (D-coded)  
for connection of an external  
CAT5 cable, e.g.  
cab-eth/M12D-RJ45-flx-(length)cab-4/USB-... or  
cab-4/USB-w-... (no picture)  
(each max. length 5m, outer jacket: PUR)



## LED Display

### LED display:

By means of the two LEDs the physical state of the two outputs OUT0 and OUT1 is visualized:

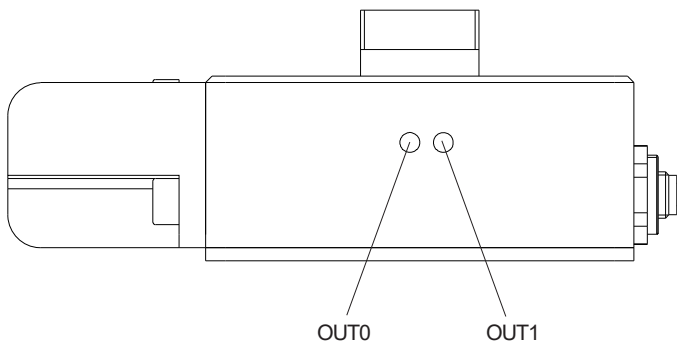

## Measuring Principle

### Measuring principle of the sensors of SPECTRO-1 series:

The sensors of the SPECTRO-1 series are of single-channel design, i.e. they acquire the analog signal that comes from a receiver and evaluate this signal. Various light sources such as white light, UV light, IR light, or a laser can be used as a transmitter. The receiver is correspondingly matched to the transmitter. The acquired analog signal is provided through a voltage output and a current output.

The software can be used to select various evaluation modes for the analog signal. The status of the analog signal is provided through 2 digital outputs in accordance with the selected evaluation mode. A digital input allows external "teaching" of the sensor. An additional input allows the "freezing" of the analog output signal upon a positive input edge.

The SPECTRO-1 sensor allows highly flexible signal acquisition. The sensor, for example, can be operated in alternating-light mode (AC mode), which means the sensor is not influenced by external light, or in constant-light mode (DC mode), which provides outstanding high-speed sensor operation. An OFF function deactivates the sensor's integrated light source and changes to DC mode, which allows the sensor to detect so-called "self-luminous objects". With the stepless adjustment of the integrated light source, the selectable gain of the receiver signal, and an INTEGRAL function the sensor can be adjusted to almost any surface or any "self-luminous object".

A micro-controller performs 12-bit analog/digital conversion of the analog signal, which allows recording and evaluation of the signal. Furthermore the SPECTRO-1 sensor offers various options for intelligent signal processing such as e.g. dirt accumulation compensation.

Parameters and measurement values can be exchanged between PC and sensor either through RS232 or Ethernet (using an Ethernet converter). Through the interface all the parameters can be stored in the non-volatile EEPROM of the sensor.

The PC software facilitates the parameterisation, diagnostics, and adjustment of the sensor system (oscilloscope function). The software furthermore provides a data recorder function that automatically records data and stores them on the hard disk of the PC.

SPECTRO-1 sensors are temperature-compensated over a range of 0°C to 80°C.



## Parameterization

### Windows® user interface:

(The current software version is available for download on our website.)



The PC software SPECTRO1-Scope facilitates the parameterization, the diagnosis, and the adjustment of the sensor system (oscilloscope function). Moreover, the software features a data recorder function that allows the automatic recording of recorded data and the saving of those at the hard disk of the PC.

Parameters and measurement values can be exchanged between PC and sensor either through RS232 or Ethernet (using an Ethernet converter). Through the interface all the parameters can be stored in the non-volatile EEPROM of the sensor.

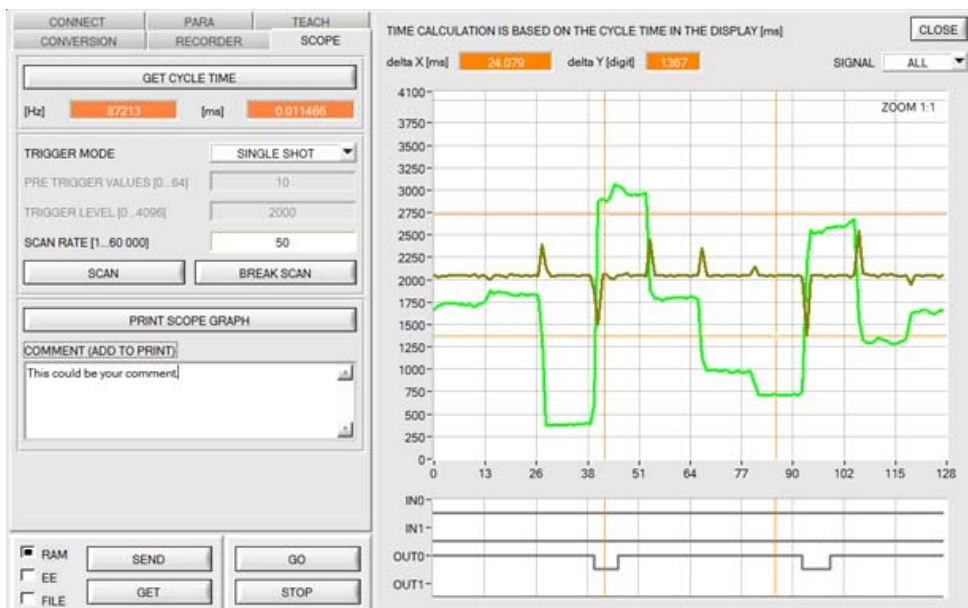

The SCOPE tab visualises an oscilloscope.

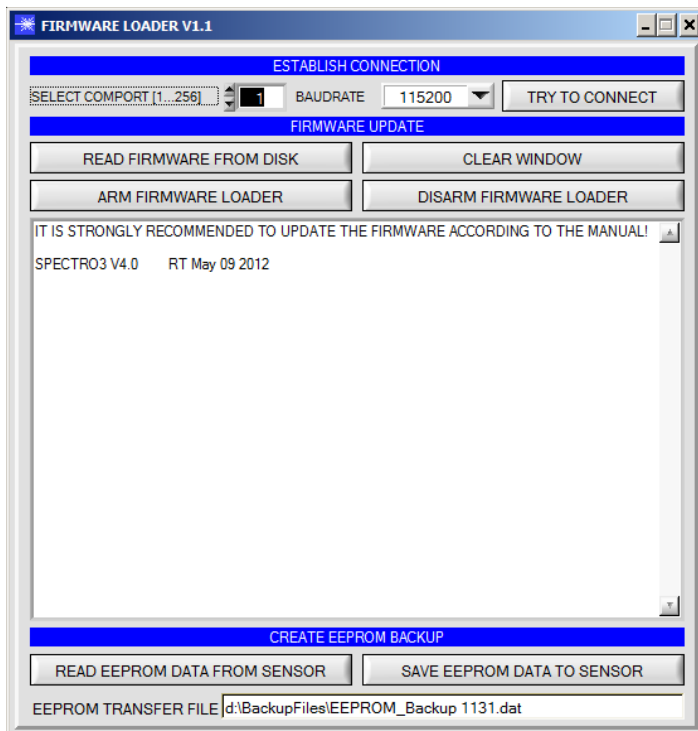
**Firmware Update****Firmware update by means of the software „FirmwareLoader“:**

The software „Firmware Loader“ allows the user to perform an automatic firmware update. The update will be carried out through the RS232 interface.

An initialisation file (xxx.ini) and a firmware file (xxx.elf.S) are required for performing a firmware update. These files can be obtained from your supplier. In some cases an additional firmware file for the program memory (xxx.elf.p.S) is also needed, and this file will be automatically provided together with the other two files.



UV Fiber Optics

Available standard fiber optics (FIO Series):

(further types of fiber optics available on request)

UV reflected light fiber optics

R-S-A1.1-(1.5)-...-22°-UV

R-S-A2.0-(2.5)-...-22°-UV

R-S-A3.0-(3.0)-...-22°-UV

R-S-R1.1-(3x0.5)-...-22°-UV

R-S-R2.1-(6x1)-...-22°-UV

(available in standard length 600mm or 1200mm)

Can be used in addition with attachment optics KL -...

UV transmitted light fiber optics

D-S-A2.0-(2.5)-...-22°-UV

D-S-A3.0-(3.0)-...-22°-UV

(available in standard length 600mm or 1200mm)

Can be used, for example, for emulsion detection (share of oil in water), without an attachment optics



Please note:

For operation with the SPECTRO-1-FIO-UV/BL solely UV light optical fibers with a beam opening angle of 22° are to be used!

Characteristics:

Light-conducting glass fibers are optical components that allow the transmission of light through any curved path based on the principle of total reflection. The individual fiber is composed of high-break core glass and low-break cladding glass. The light beams entering the core glass within the critical angle are guided through the fiber by way of reflection at the core/cladding contact surfaces (step index fiber). The highly flexible optical fibers are made of bundled individual glass fibers. The ends are each glued into a sensor head and a connector. The faces are optically polished. For protection against mechanical, chemical, or thermal destruction the optical fibers are provided with a corresponding protective sheath.

Order Code:

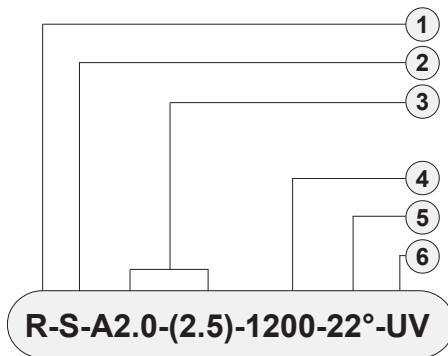

R-S-A2.0-(2.5)-1200-22°-UV

Order code for optical fiber

(For detailed description of the various types of fiber optics please cf. catalog „FIO Series“)

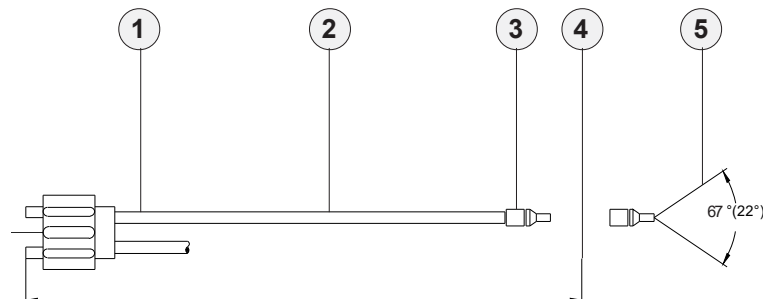

Dimensions of adapter

Attachment optics (e.g. focus lens, reflex optics, prismn optics)

Fiber optics for reflex light operation

Fiber optics for transmitted light operation

Mounting hints

cf. catalog FIO Series

cf. catalog FIO Series

cf. catalog FIO Series

cf. catalog FIO Series

cf. catalog FIO Series





Optical Frontends

Optical frontends for UV reflected light fiber optics (22°-UV):



KL-3-A2.0  
KL-4-A1.1  
KL-5-R1.1  
KL-8-R2.1  
KL-9-A3.0



KL-M8-A1.1



KL-M12-A1.1  
KL-M12-A2.0  
KL-M12-A3.0  
KL-M12-R1.1



KL-M12-XL-A1.1  
KL-M12-XL-A2.0  
KL-M12-XL-R1.1



KL-M18-A1.1  
KL-M18-A2.0  
KL-M18-A3.0  
KL-M18-R1.1  
KL-M18-R2.1



KL-M18-XL-A1.1  
KL-M18-XL-A2.0  
KL-M18-XL-A3.0  
KL-M18-XL-R1.1  
KL-M18-XL-R2.1



KL-M34-A1.1  
KL-M34-A2.0  
KL-M34-A3.0  
KL-M34-R1.1  
KL-M34-R2.1



KL-M34-XL-A1.1  
KL-M34-XL-A2.0  
KL-M34-XL-A3.0  
KL-M34-XL-R1.1  
KL-M34-XL-R2.1



KL-M34/62-A1.1  
KL-M34/62-A2.0  
KL-M34/62-A3.0  
KL-M34/62-R1.1  
KL-M34/62-R2.1



**Optical Frontends**

**Optical frontends for UV reflected light fiber optics (22°-UV):**

Part number:	Suitable for fiber optics type: (R = reflected light)	Characteristics:
KL-3-A2.0	R-S-A2.0-(2.5)-...-22°-UV	Working distance typ. 10 mm ... 20 mm
KL-4-A1.1	R-S-A1.1-(1.5)-...-22°-UV	Working distance typ. 10 mm ... 15 mm
KL-5-R1.1	R-S-R1.1-(3x0.5)-...-22°-UV	Working distance typ. 8 mm ... 20 mm
KL-8-R2.1	R-S-R2.1-(6x1)-...-22°-UV	Working distance typ. 8 mm ... 25 mm
KL-9-A3.0	R-S-A3.0-(3.0)-...-22°-UV	Working distance typ. 8 mm ... 25 mm
KL-M8-A1.1	R-S-A1.1-(1.5)-...-22°-UV	Working distance typ. 8 mm ... 20 mm
KL-M12-A1.1	R-S-A1.1-(1.5)-...-22°-UV	Working distance typ. 8 mm ... 20 mm
KL-M12-A2.0	R-S-A2.0-(2.5)-...-22°-UV	Working distance typ. 8 mm ... 20 mm
KL-M12-A3.0	R-S-A3.0-(3.0)-...-22°-UV	Working distance typ. 8 mm ... 20 mm
KL-M12-R1.1	R-S-R1.1-(3x0.5)-...-22°-UV	Working distance typ. 8 mm ... 20 mm
KL-M12-XL-A1.1	R-S-A1.1-(1.5)-...-22°-UV	Working distance typ. 30 mm ... 100 mm
KL-M12-XL-A2.0	R-S-A2.0-(2.5)-...-22°-UV	Working distance typ. 30 mm ... 100 mm
KL-M12-XL-R1.1	R-S-R1.1-(3x0.5)-...-22°-UV	Working distance typ. 30 mm ... 100 mm
KL-M18-A1.1	R-S-A1.1-(1.5)-...-22°-UV	Working distance typ. 10 mm ... 60 mm
KL-M18-A2.0	R-S-A2.0-(2.5)-...-22°-UV	Working distance typ. 10 mm ... 80 mm
KL-M18-A3.0	R-S-A3.0-(3.0)-...-22°-UV	Working distance typ. 10 mm ... 80 mm
KL-M18-R1.1	R-S-R1.1-(3x0.5)-...-22°-UV	Working distance typ. 10 mm ... 60 mm
KL-M18-XL-A1.1	R-S-A1.1-(1.5)-...-22°-UV	Working distance typ. 50 mm ... 100 mm
KL-M18-XL-A2.0	R-S-A2.0-(2.5)-...-22°-UV	Working distance typ. 50 mm ... 100 mm
KL-M18-XL-A3.0	R-S-A3.0-(3.0)-...-22°-UV	Working distance typ. 50 mm ... 100 mm
KL-M18-XL-R1.1	R-S-R1.1-(3x0.5)-...-22°-UV	Working distance typ. 50 mm ... 100 mm
KL-M18-XL-R2.1	R-S-R2.1-(6x1)-...-22°-UV	Working distance typ. 50 mm ... 100 mm
KL-M34-A1.1	R-S-A1.1-(1.5)-...-22°-UV	Working distance typ. 50 mm ... 100 mm
KL-M34-A2.0	R-S-A2.0-(2.5)-...-22°-UV	Working distance typ. 50 mm ... 100 mm
KL-M34-A3.0	R-S-A3.0-(3.0)-...-22°-UV	Working distance typ. 50 mm ... 100 mm
KL-M34-R1.1	R-S-R1.1-(3x0.5)-...-22°-UV	Working distance typ. 50 mm ... 100 mm
KL-M34-R2.1	R-S-R2.1-(6x1)-...-22°-UV	Working distance typ. 50 mm ... 100 mm
KL-M34-XL-A1.1	R-S-A1.1-(1.5)-...-22°-UV	Working distance typ. 50 mm ... 100 mm
KL-M34-XL-A2.0	R-S-A2.0-(2.5)-...-22°-UV	Working distance typ. 50 mm ... 100 mm
KL-M34-XL-A3.0	R-S-A3.0-(3.0)-...-22°-UV	Working distance typ. 50 mm ... 100 mm
KL-M34-XL-R1.1	R-S-R1.1-(3x0.5)-...-22°-UV	Working distance typ. 50 mm ... 100 mm
KL-M34-XL-R2.1	R-S-R2.1-(6x1)-...-22°-UV	Working distance typ. 50 mm ... 100 mm
KL-M34/62-A1.1	R-S-A1.1-(1.5)-...-22°-UV	Working distance typ. 80 mm ... 100 mm
KL-M34/62-A2.0	R-S-A2.0-(2.5)-...-22°-UV	Working distance typ. 80 mm ... 100 mm
KL-M34/62-A3.0	R-S-A3.0-(3.0)-...-22°-UV	Working distance typ. 80 mm ... 100 mm
KL-M34/62-R1.1	R-S-R1.1-(3x0.5)-...-22°-UV	Working distance typ. 80 mm ... 100 mm
KL-M34/62-R2.1	R-S-R2.1-(6x1)-...-22°-UV	Working distance typ. 80 mm ... 100 mm