

SPECTRO Series

► SPECTRO-3-20-DIF-MSM-DIG-DL

- Color measurement (color, contrast, and gray scale detection)
- Object distance (measuring range) 20 mm ± 1 mm
- Reduction of gloss effect due to diffuse illumination (volume lens serves as a diffusor, for optimal scattering effect)
- L*a*b*, L*C*h*, L*u*v*, L*u'v' and xyY evaluation (CIE standard)
- Up to 31 colors (max. 48 in group mode) can be stored
- 40x D65 similar LED
(AC-, DC-operation can be switched)
- Insensitive to outside light (in AC-operation)
- Scan frequency max. 35 kHz (in DC-operation)
- Switching frequency typ. 60 kHz
- 5 digital outputs to output taught colors
- TEACH via PC or external input
- Various evaluation algorithms can be activated
- "BEST HIT" mode ("human color assessment")
- Averaging can be activated (from 1 up to over 32000 values)
- Parameterizable via Windows® software, scope function
- RS232 interface (USB or Ethernet converter is available)
- Temperature compensated
- 3-color filter detector (true color detector: "human color perception")
- Integrated cooling device for protection against overheating of the sensor
- Spacer available as an option

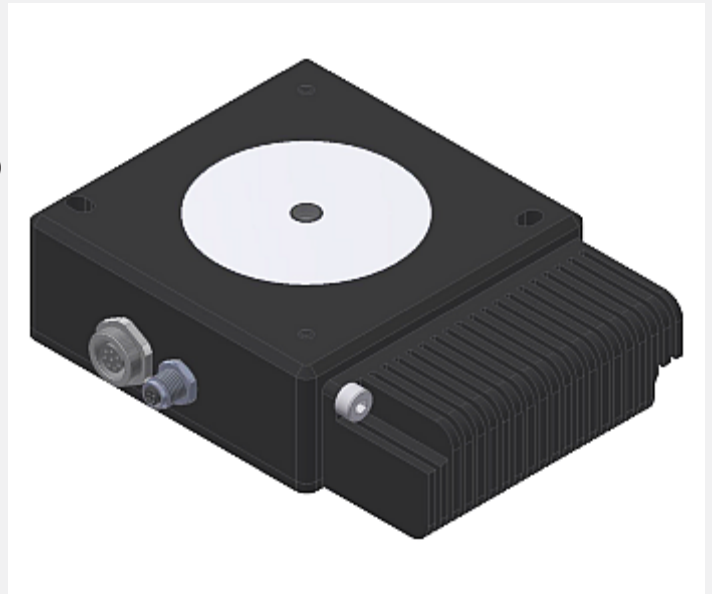

Aufbau

Product name:

SPECTRO-3-20-DIF-MSM-DIG-DL

(incl. Windows® PC software
SPECTRO3-MSM-DIG-Scope)

Accessories: (p. 8-9)

SPECTRO-3-20-DIF-OFL
(Spacer)

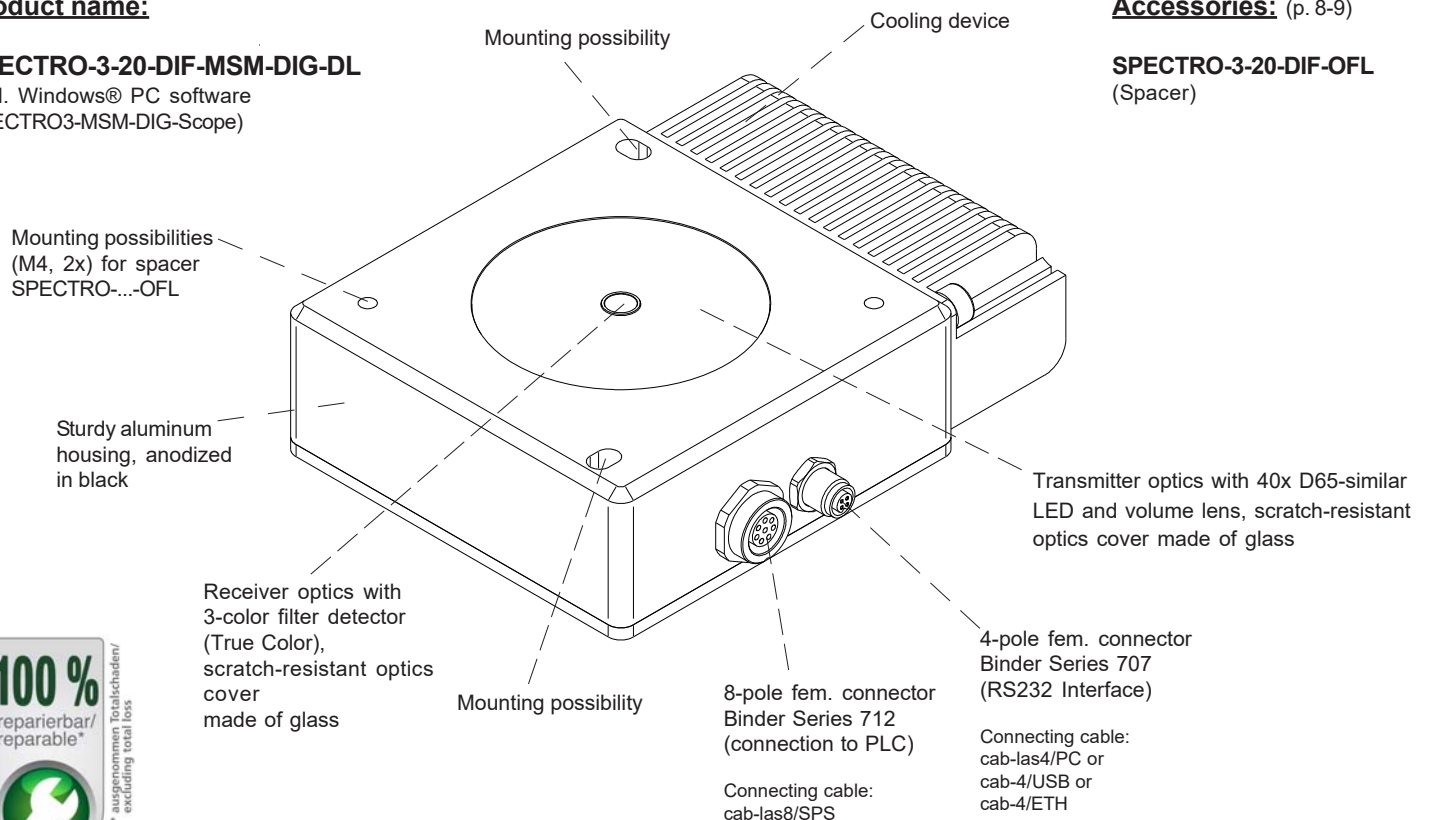



Technical Data

Type	SPECTRO-3-20-DIF-MSM-DIG-DL
Voltage supply	+24VDC (± 10%), reverse polarity protected, overcurrent protected
Current consumption	< 1.2 A
Max. switching current	100 mA, short circuit proof
Input digital (1x)	IN0 (Pin 3), digital (0V/+24V)
Outputs digital (5x)	OUT0 ... OUT4 (Pin 4 ... 8): digital (0V/+24V), npn-/pnp-able (bright-/dark-switching, can be switched)
Interface	RS232 (an external USB and ETHERNET converter is available)
Pulse lengthening	0 ... 100 ms, adjustable via PC software
Averaging	max. 32768 values, adjustable via PC software
Scan frequency	LED operation, can be switched via PC software: AC operation: max. 20 kHz (depends on parameterization) DC operation: max. 35 kHz (depends on parameterization)
Switching frequency	typ. 60 kHz
Transmitter (light source)	40x D65 similar LED, volume lens as diffusor
Transmitter control	can be switched via PC software: AC operation (LED MODE-AC), DC operation (LED MODE-DC)
Object distance (measuring range)	typ. 20 mm ± 1 mm
Receiver	3-color filter detector (TRUE COLOR detector, "human color perception"), color filter curves acc. to CIE 1931
Receiver gain setting	8 steps (AMP1 ... AMP8), adjustable via PC software
Ambient light	max. 5000 Lux
Detection range (half intensity width)	typ. 5 mm at a distance of 12 mm
Reproducibility	in the X, Y color range each 1 digit at 12-bit A/D conversion
Temperature drift X,Y	$\Delta X/\Delta T$; $\Delta Y/\Delta T$ typ. 0,2 digits/°C (< 0,01% / °C)
Measuring accuracy	typ. $\Delta E = 0.3$
Resolution	$\Delta E \geq 0.01$ in case of color space L*u*v': $\Delta u'v' = 0.001$
Color space (resolution)	CIE L*a*b* , CIE L*C*h* , CIE L*u*v* , CIE L*u'v' , and CIE xyY
Color memory capacity	non-volatile EEPROM with parameter sets for max. 31 colors (max. 48 in group mode)
Housing dimensions	LxWxH approx. 80 mm x 80 mm x 110 mm (without flange connectors)
Housing material	aluminum, anodized in black
Enclosure rating	IP64
Connecting cables	to PLC: cab-las8/SPS or cab-las8/SPS-w to PC/RS232 interface: cab-las4/PC or cab-las4/PC-w to PC/USB interface: cab-4/USB or cab-4/USB-w to PC/Ethernet interface: cab-4/ETH
Type of connector	connection to PLC: 8-pole fem. connector (Binder 712), connection to PC: 4-pole fem. connector (Binder 707)
Operating temp. range	-20°C ... +55°C
Storage temperature range	-20°C ... +85°C
EMC test acc. to	DIN EN 60947-5-2

Dimensions

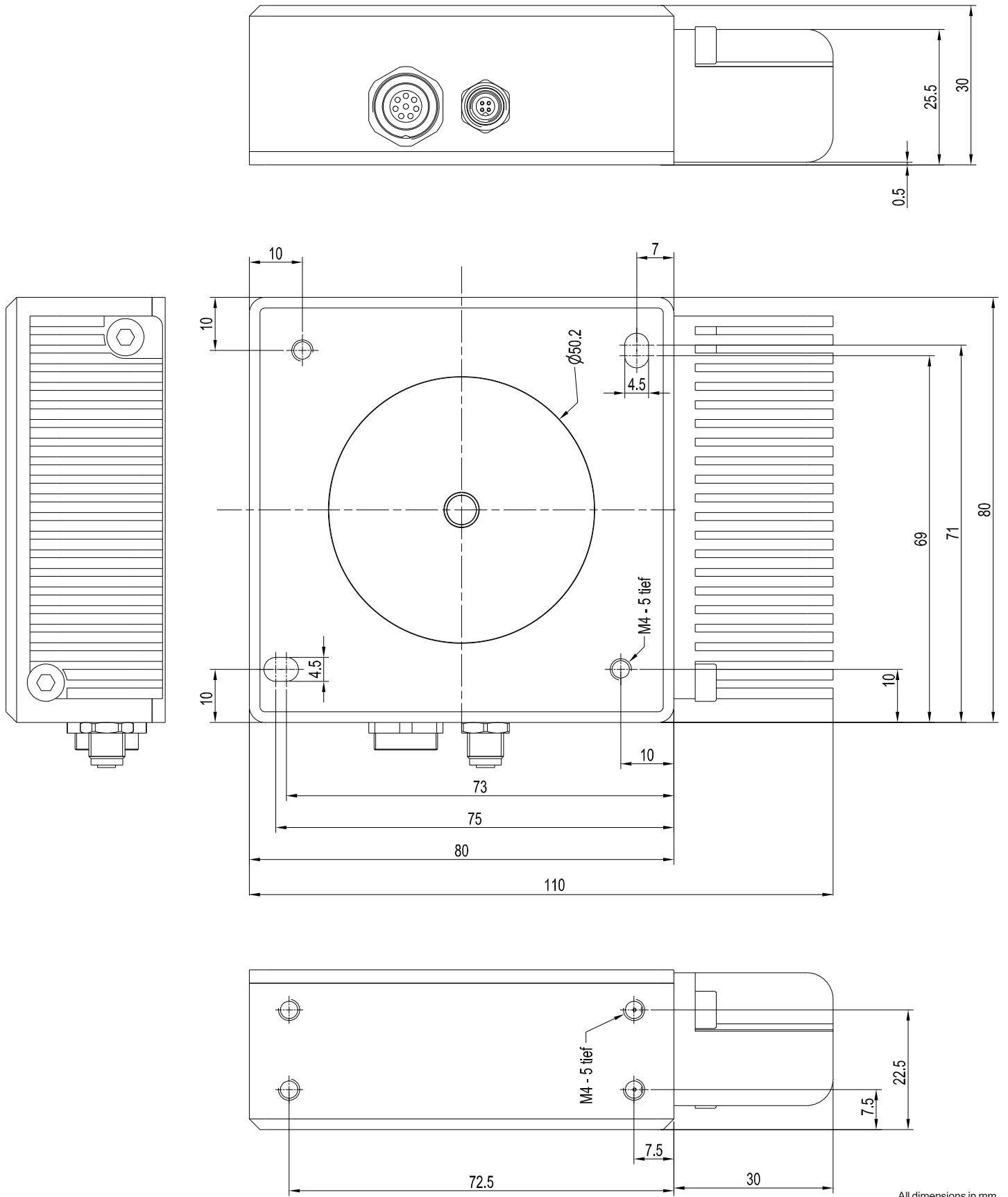

All dimensions in mm



Connector Assignment

Connection to PLC:

8-pole fem. connector Binder Series 712

Pin:	Color:	Assignment:
1	white	GND (0V)
2	brown	+24VDC ($\pm 10\%$)
3	green	IN0
4	yellow	OUT0 (Digital 0: typ. 0...1V, Digital 1: typ. +Ub - 10%)
5	grey	OUT1 (Digital 0: typ. 0...1V, Digital 1: typ. +Ub - 10%)
6	pink	OUT2 (Digital 0: typ. 0...1V, Digital 1: typ. +Ub - 10%)
7	blue	OUT3 (Digital 0: typ. 0...1V, Digital 1: typ. +Ub - 10%)
8	red	OUT4 (Digital 0: typ. 0...1V, Digital 1: typ. +Ub - 10%)

Connecting cable:

[cab-las8/SPS-\(length\)](#)

[cab-las8/SPS-w-\(length\)](#) (angle type, 90°)

(standard length 2m)

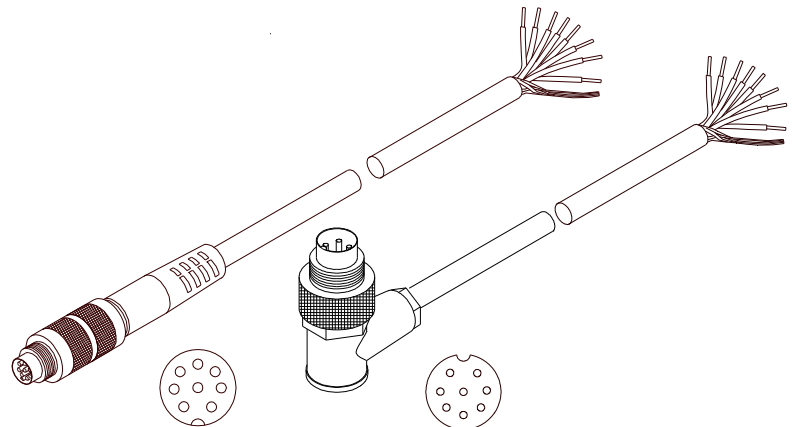

[cab-las8/SPS-...](#)
(max. length 25m, outer jacket: PUR)

[cab-las8/SPS-w-...](#)
(max. length 25m, outer jacket: PUR)

Connection to PC:

4-pole fem. connector Binder Series 707

Pin:	Assignment:
1	+24VDC (+Ub, OUT)
2	GND (0V)
3	RxD
4	TxD

Connection via RS232 interface at the PC:

Connecting cable:

[cab-las4/PC-\(length\)](#)

[cab-las4/PC-w-\(length\)](#) (angle type 90°)

(standard length 2m)

alternative:

Connection via USB interface at the PC:

USB converter (incl. driver software):

[cab-4/USB-\(length\)](#)

[cab-4/USB-w-\(length\)](#) (angle type 90°)

(standard length 2m)

alternative:

Connection to local network via Ethernet bus:

Ethernet converter (incl. software „SensorFinder“):

[cab-4/ETH-500](#)

(standard length 0.5m)

Optional: External CAT5 cable, e.g.

[cab-eth/M12D-RJ45-flx-\(length\)](#)

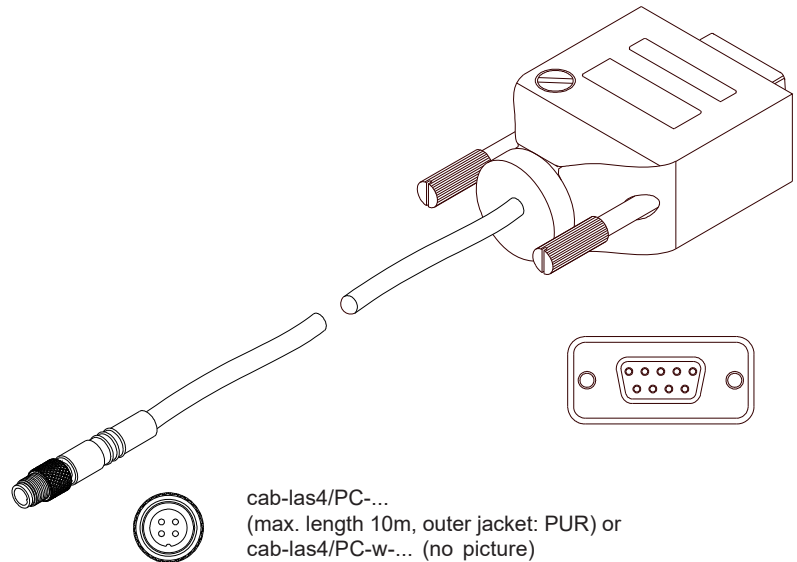

[cab-las4/PC-...](#)
(max. length 10m, outer jacket: PUR) or
[cab-las4/PC-w-...](#) (no picture)
(max. length 5m, outer jacket: PUR)

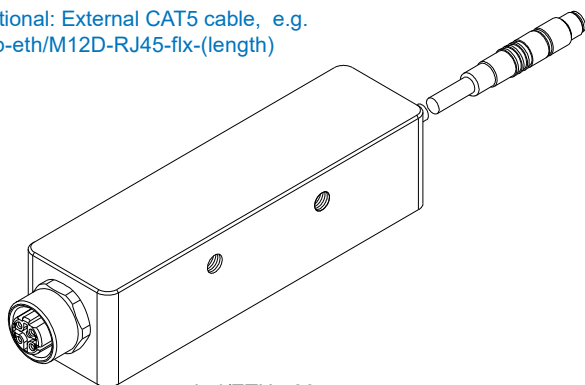

[cab-4/ETH-500](#)
(length 0.5m, outer jacket: PUR)
4-pole M12 fem. conn. (D-coded)
for connection of an external
CAT5 cable, e.g.
[cab-eth/M12D-RJ45-flx-\(length\)](#)

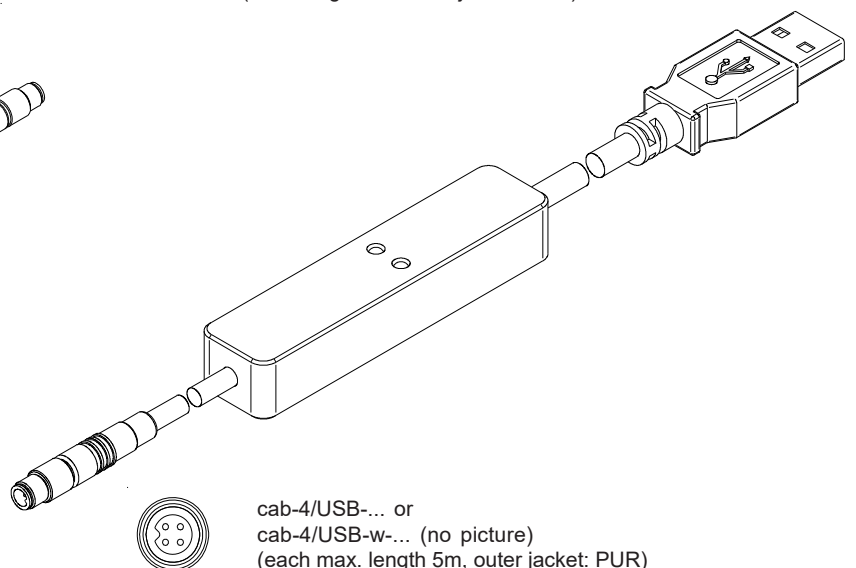

[cab-4/USB-...](#) or
[cab-4/USB-w-...](#) (no picture)
(each max. length 5m, outer jacket: PUR)

**Measuring Principle****Measuring principle of the color sensors of SPECTRO-3-MSM-DIG series:**

The SPECTRO-3-MSM-DIG provides highly flexible signal acquisition. For example, the sensor can be operated in alternating-light mode (AC mode), which makes the sensor insensitive to extraneous light. It also can be set to constant-light mode (DC mode), which makes the sensor extremely fast. With the stepless adjustment of the integrated light source as well as the selectable gain of the receiver signal and an INTEGRAL function the sensor can be set to almost any surface or any "self-luminous object".

When the integrated light source of the SPECTRO-3-MSM-DIG color sensor is activated, the sensor detects the radiation that is diffusely reflected from the object. As a light source the SPECTRO-3-MSM-DIG color sensor uses LEDs (in case of color sensor type -VISUV additionally UV LEDs) with adjustable transmitter power. An integrated 3-fold receiver for the red, green, and blue content of the light that is reflected from the object, or the light that is emitted by a "self-luminous object", is used as a receiver.

The color sensors of the SPECTRO-3-MSM-DIG series can be taught up to 31 colors that are provided directly at the outputs, and up to 48 colors that are output by means of grouping. For each of these taught colors it is possible to set tolerances. Evaluation of the taught colors is performed either with the "FIRST HIT" or with the "BEST HIT" mode. With "FIRST HIT" the first hit in the teach table is output, and with "BEST HIT" the best hit in the teach table is output. Raw data are represented with 12 bit resolution.

Color detection either operates continuously or is started through an external PLC trigger signal. The respective detected color either is provided as a binary code at the 5 digital outputs or can be sent directly to the outputs, if only up to 5 colors are to be detected. At the same time the detected color code is visualised by means of 5 LEDs at the housing of the SPECTRO-3-MSM-DIG. **[Please note: Visualisation by means of LEDs not available with SPECTRO-3-JR-MSM-DIG types.]**

With a TEACH button at the sensor housing the color sensor can be taught up to 31 colors (max. 48 colors in group mode). For this purpose the corresponding evaluation mode must be set with the software. The TEACH button is connected in parallel to the input IN0 (green wire at cable cab-las8/SPS). **[Please note: TEACH button not available with SPECTRO-3-JR-MSM-DIG types.]**

Parameters and measurement values can be exchanged between a PC and the SPECTRO-3-MSM-DIG color sensor through the serial RS232 interface. All the parameters for color detection also can be saved to the non-volatile EEPROM of the SPECTRO-3-MSM-DIG color sensor through this serial RS232 interface. When parameterisation is finished, the color sensor continues to operate with the current parameters in STAND-ALONE mode without a PC.

Possible firmware updates can be easily performed through the RS232 interface, even with the sensor system in installed condition (a firmware update is performed via the software „FirmwareLoader“).

The sensors of the SPECTRO-3-MSM-DIG series can be calibrated. Calibration can be performed to any surface with known color coordinates. A ColorChecker™ table is available as an alternative. This table has 24 color fields according to the CIE STANDARD that can be used for calibration.



Parameterization
Windows® user interface:

(The current software version is available for download on our website.)

The color sensor is parameterized under Windows® with the SPECTRO3-MSM-DIG-Scope software. The Windows® user interface facilitates the teach-in process at the color sensor and supports the operator in the task of adjustment and commissioning of the color sensor.

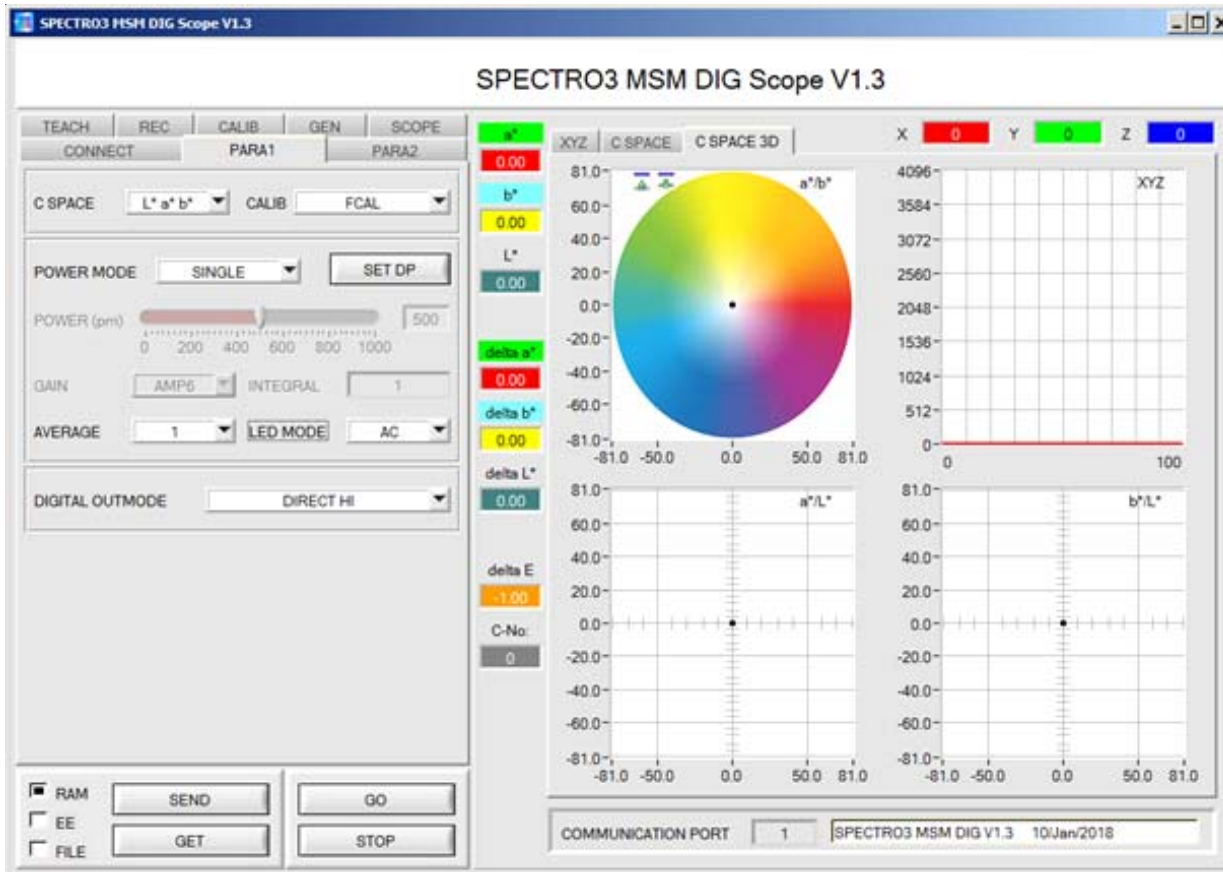

The RS232 interface (tab PARA1) is used for setting parameters such as:

- POWER MODE: Light power of the LED
 - SET DP: Set Double Parameter
 - LED MODE: Triggering of the internal light source (AC, DC)
 - GAIN: Used for setting the gain of the receiver (AMP1 ... AMP8)
 - AVERAGE: Number of scanning values (measurement values, 1 ... 32768) over which the raw signal measured at the receiver is averaged. A higher AVERAGE default value reduces noise of the raw signals at the receiver unit and there will be a decrease of the maximal available switching frequency of the sensor.
 - INTEGRAL: Number of scan values (measurement values) over which the raw signal measured at the receiver is summed up. This integral function allows the reliable detection even of extremely weak signals
 - C SPACE: Selection of a color space ($L^*a^*b^*$, $L^*C^*h^*$, $L^*u^*v^*$, $L^*u^*v^*$, or xyY) for the calculation of the color stimulus specification
 - DIGITAL OUTMODE: Triggering of the five digital outputs (OUT0 ... OUT4)
 - EVALUATION MODE: Evaluation mode (FIRST HIT or BEST HIT)
 - TRIGGER: Continuous or external or self trigger (CONT, EXT1, EXT2, TRANS)
 - EXTEACH: In all the evaluation modes teaching of a color can be performed externally through IN0 or by means of the button at the sensor housing [TEACH button not available with SPECTRO-3-JR-MSM-DIG types.]
 - INTLIM: Minimum intensity required for color evaluation
 - MAXCOL-No.: Number of colors to be checked
- Tab TEACH Opens a window where you can teach colors to the TEACH TABLE
 Tab CALIB Selection of calibration mode (FCAL = factory calibration or UCAL = user calibration).
 Tab SCOPE Visualises an oscilloscope
 Tab GEN Displays the current temperature value TEMP in the sensor housing
 Tab REC Data recorder



Firmware Update

Firmware update by means of the software „FirmwareLoader“:



The software „Firmware Loader“ allows the user to perform an automatic firmware update. The update will be carried out through the RS232 interface.

An initialisation file (xxx.ini) and a firmware file (xxx.elf.S) are required for performing a firmware update. These files can be obtained from your supplier. In some cases an additional firmware file for the program memory (xxx.elf.p.S) is also needed, and this file will be automatically provided together with the other two files.



Spacer

**SPECTRO-3-20-DIF-OFL
Spacer**

(please order separately)

Spacer (offline unit) for color sensor
SPECTRO-3-20-DIF-MSM-DIG-DL

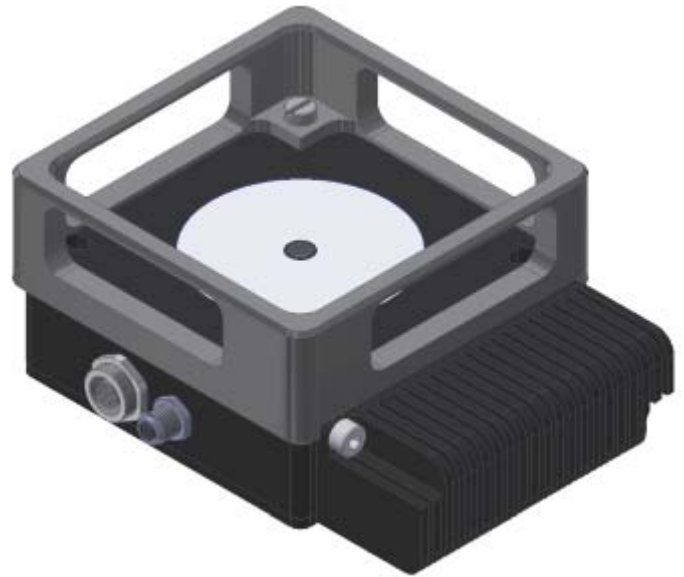

Picture above shows:
SPECTRO-3-20-DIF-MSM-DIG-DL with
SPECTRO-3-20-DIF-OFL

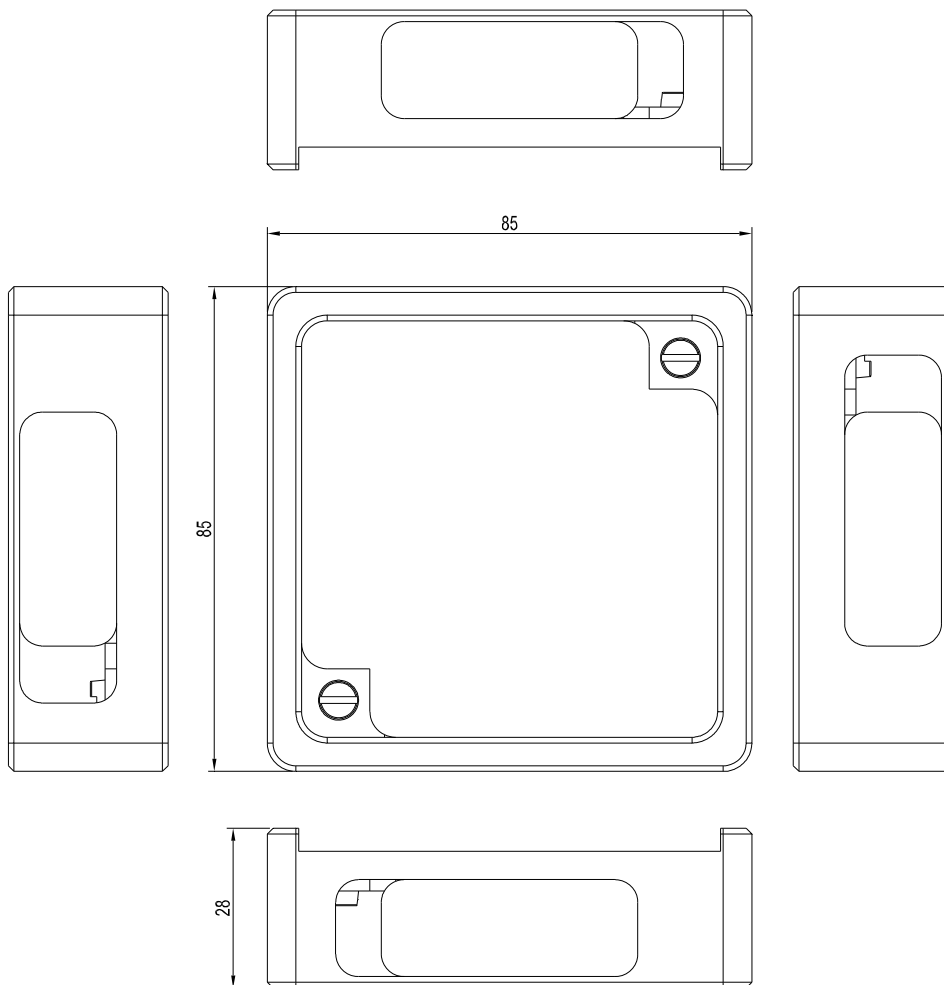

All dimensions in mm



Spacer

Reference distance with SPECTRO-3-20-DIF-OFL spacer mounted on color sensor SPECTRO-3-20-DIF-MSM-DIG-DL

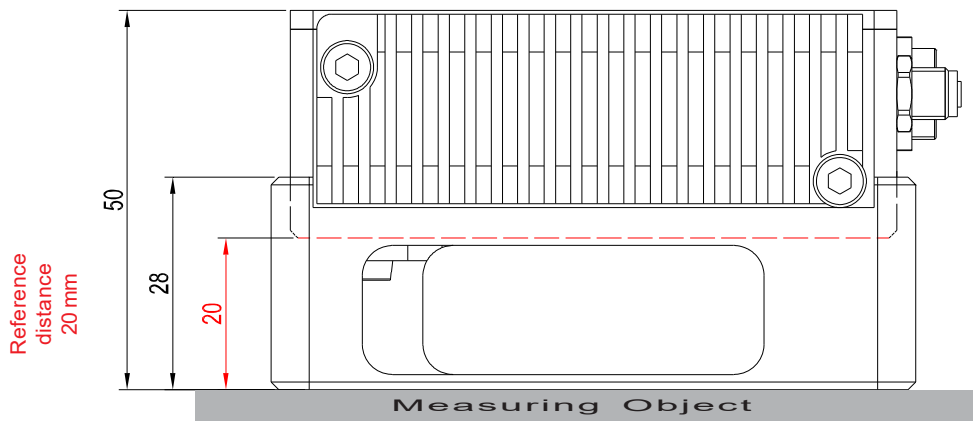
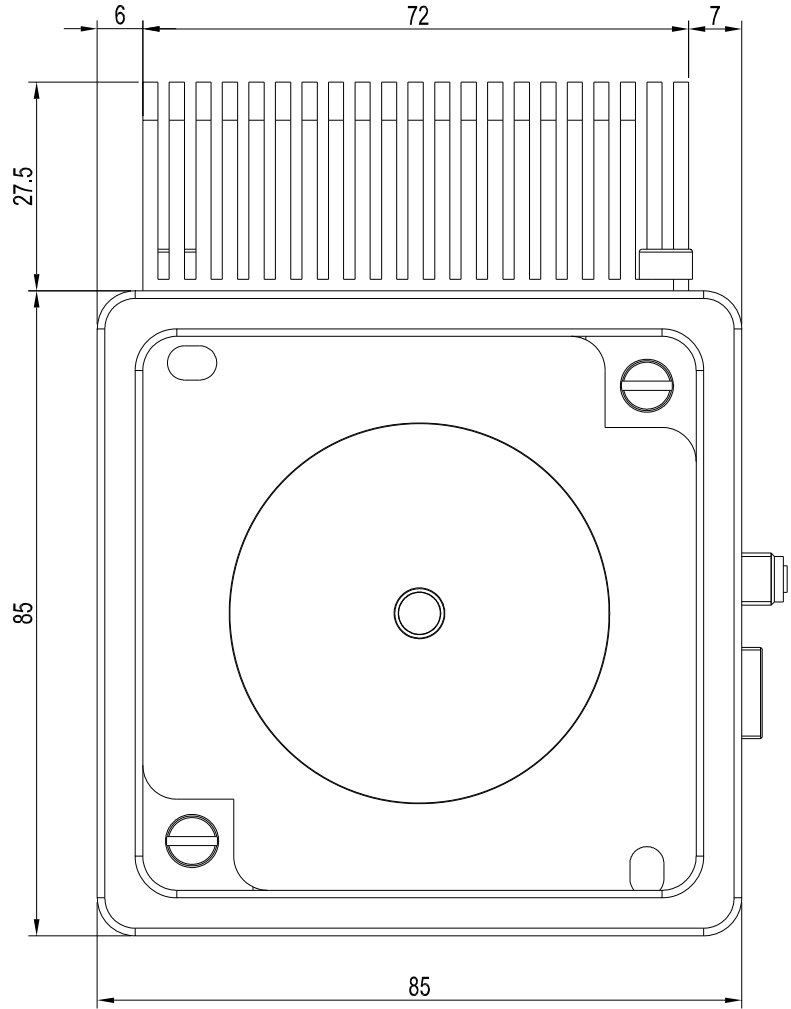

All dimensions in mm