

A-LAS Series

▶ A-LAS-F08-...-C

- Analog signal (0...+10V) in connection with an electronic control unit type AGL4, AGL4-HS, AGL-DIF, SI-CON11 (without PC connection) or SI-CON8, SI-CON34, A-LAS-CON1 (with PC connection and software)
 (stand-alone operation of the light barrier is not possible)
- Parallel aligned, visible red laser beam (<0.39 mW, 670 nm), **laser class 1**
- Various apertures and fork sizes available
- Measuring range up to 3 mm (depends on aperture used)
- Working range = fork width
- Insensitive to outside light due to interference filter
- Compact design, sturdy metal housing, IP67

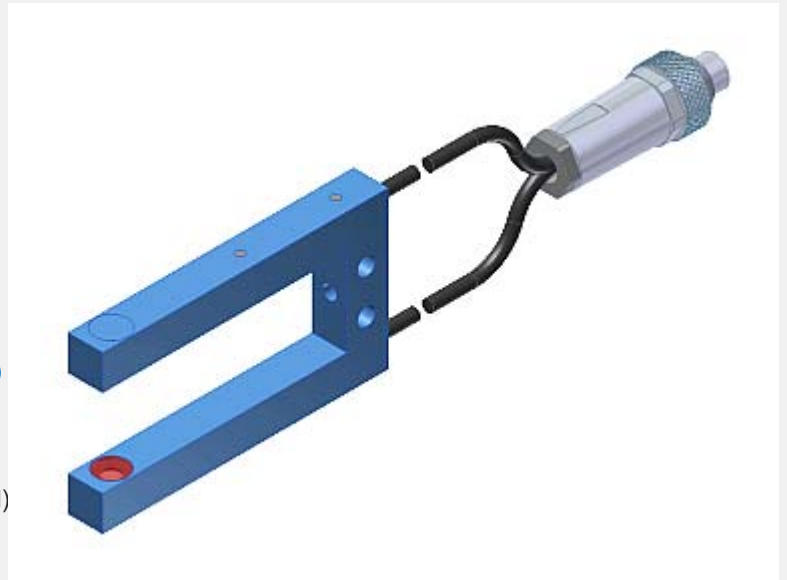

Design

Product name:

A-LAS-F08-(aperture)*-(fork size)-C-1m**

***Available apertures:**

Round apertures d... (mm):

- d0.15
- d0.2
- d0.3
- d0.5
- d0.7
- d1.0
- d2.0

Rectangular apertures AxB (mm):

- | | |
|---------|---------|
| 0.2x0.5 | 1.5x0.3 |
| 0.2x1 | 2x0.5 |
| 0.3x0.5 | 2x0.75 |
| 0.3x0.8 | 2x1 |
| 0.3x1 | 3x0.5 |
| 0.3x1.5 | 3x0.75 |
| 0.5x0.2 | 3x1 |
| 0.5x0.3 | |

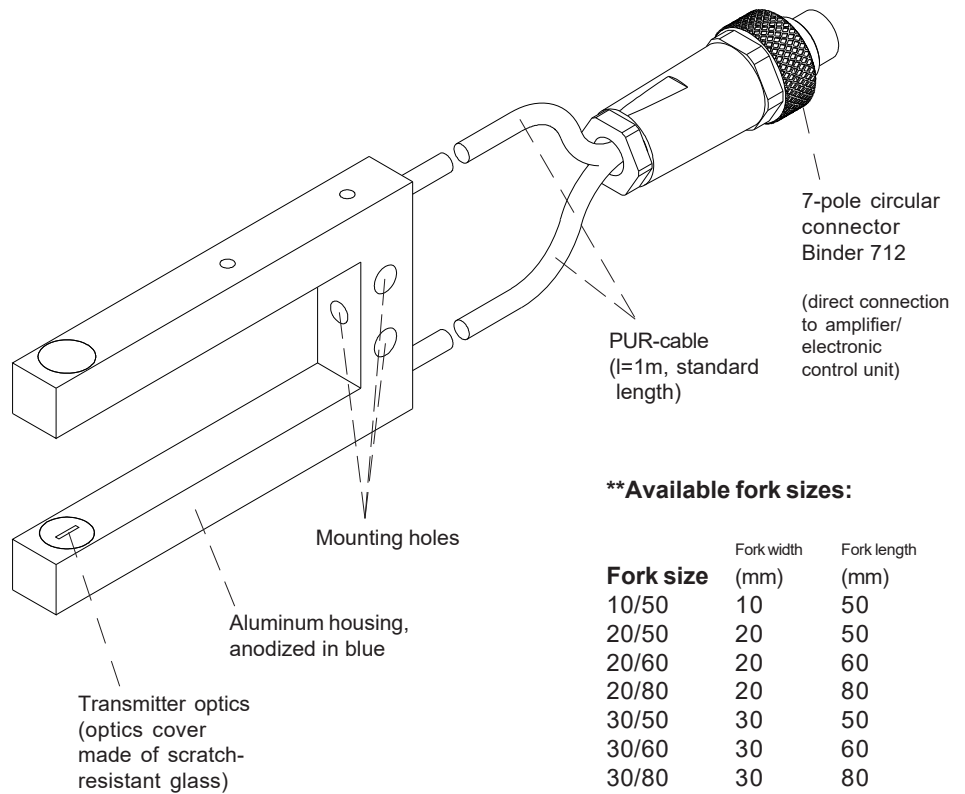
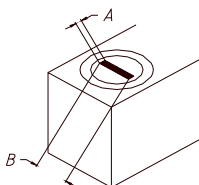
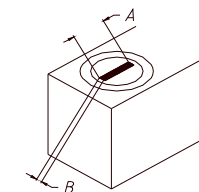

****Available fork sizes:**

Fork size	Fork width (mm)	Fork length (mm)
10/50	10	50
20/50	20	50
20/60	20	60
20/80	20	80
30/50	30	50
30/60	30	60
30/80	30	80
40/50	40	50
40/60	40	60
40/80	40	80
50/50	50	50
50/60	50	60
50/80	50	80
100/50	100	50
100/80	100	80



Technical Data

Type	A-LAS-F08-...-C
Shape	Laser light barrier in fork shape with 8 mm thick housing. Various round or rectangular apertures are available.
Laser	Solid-state laser, 670 nm, DC-operation, 0.39 mW max. opt. power, laser class 1 acc. to DIN EN 60825-1. The use of these laser transmitter therefore requires no additional protective measures.
Available aperture sizes	Cf. page 1
Measuring range	Up to 3 mm (depends on the aperture used)
Working range	Working range = fork width
Min. detectable object	Typ. 1% of aperture size
Reproducibility	Typ. 1% of aperture size, with threshold correction (via electronic control unit): typ. 0.1% of aperture size
Threshold correction	Can be activated via a software-controlled electronics of type A-LAS-CON1, SI-CON8, or SI-CON34
Optical filters	Red light filter RG 630 and interference filter
Voltage supply	Transmitter: +5VDC, receiver: +5VDC
Ambient light (outside light)	With 5000 Lux ambient light around optical receiver unit typ. < 300mV influence on analog signal (0...+10V)
Analog output	0 ... +10V (in connection with any electronic control unit of A-LAS Series)
Band width analog signal	100 kHz (-3 dB)
Current control input (I-CONTROL)	0V ... 5V, laser power decreases linear to increase of voltage: 0V: full power, 5V: laser off
Sensitivity setting (switching threshold)	Via software (with control electronics A-LAS-CON1, SI-CON34, or SI-CON8) or via potentiometer (with control electronics AGL4 or AGL4-HS)
Gain (analog signal)	Via software (with control electronics A-LAS-CON1, SI-CON34, or SI-CON8) or via potentiometer (with control electronics AGL4, AGL4-HS, AGL-DIF, or SI-CON11)
Current consumption	Transmitter: typ. 50 mA, receiver typ. 20 mA
Operating temperature range	0°C ... +50°C
Storage temperature range	-20°C ... +85°C
Type of connector	7-pole M8-connector, receiver: 4-pole M8-connector
Cable length	1m
Housing material	Aluminum, anodized in blue
Housing dimensions	Cf. page 3
Enclosure rating	IP67
EMC test acc. to	DIN EN 60947-5-2 



Laser Information

The laser transmitters of A-LAS series comply with laser class 1 according to EN 60825-1. Under reasonably foreseeable conditions a class 1 laser is safe. The reasonably foreseeable conditions are kept during specified normal operation. The use of these laser transmitters therefore requires no additional protective measures.

The laser transmitters of A-LAS series series are supplied with an information label „CLASS 1 Laser Product“.



Class 1 Laser Product
IEC 60825-1: 2014
P<0.39 mW; λ=670 nm
COMPLIES WITH 21 CFR 1040.10 AND 1040.11
EXCEPT FOR CONFORMANCE WITH IEC 60825-1
ED. 3, AS DESCRIBED IN
LASER NOTICE NO. 56, DATED MAY 8, 2019.

Dimensions

A-LAS-F08-...-C with fork size 10/50:

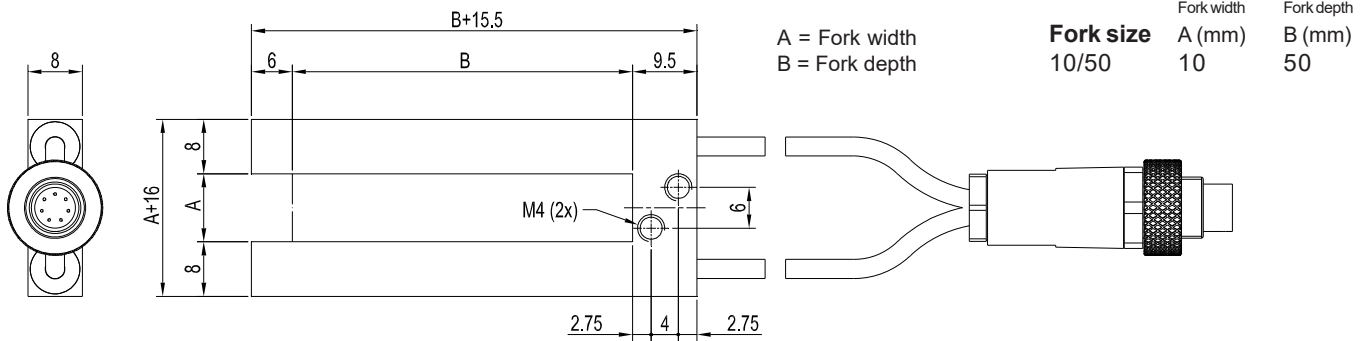

A-LAS-F08-...-C from fork size 20/50:

All dimensions in mm

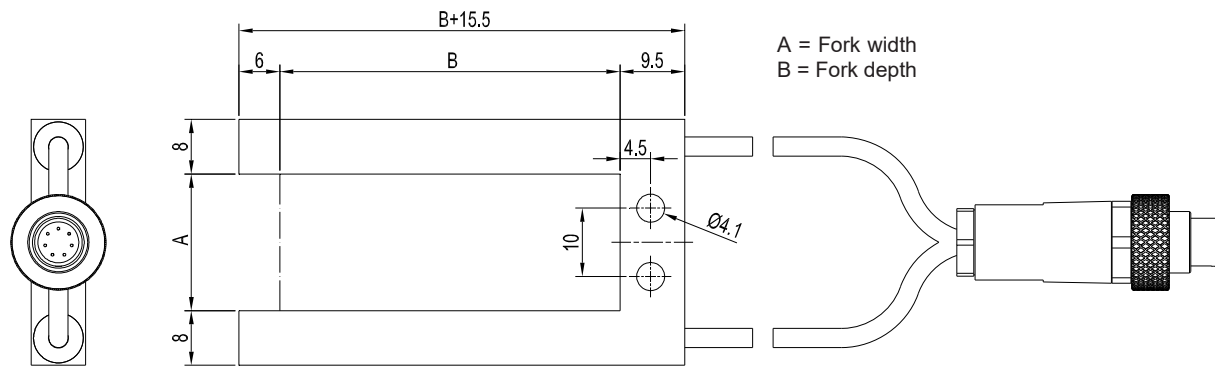

Fork size	Fork width A (mm)	Fork depth B (mm)
20/50	20	50
20/60	20	60
20/80	20	80
30/50	30	50
30/60	30	60
30/80	30	80

Fork size	Fork width A (mm)	Fork depth B (mm)
40/50	40	50
40/60	40	60
40/80	40	80
50/50	50	50
50/60	50	60
50/80	50	80

Fork size	Fork width A (mm)	Fork depth B (mm)
100/50	100	50
100/80	100	80

Connector Assignment

Connection to electronic control unit via 7-pole circular connector Binder Series 712:

Pin-No.:	Assignment:
1	0V (GND)
2	+5V
3	I-CONTROL (0V...+5V)
4	+5V
5	ANALOG
6	n.c.
7	0V (GND)

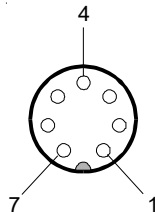

Connection directly to an electronic control unit from A-LAS Series: AGL4, AGL4-HS, AGL-DIF, SI-CON11, SI-CON8, SI-CON34, A-LAS-CON1



Electronic Control Units

Suitable electronic control units for A-LAS-...-C:

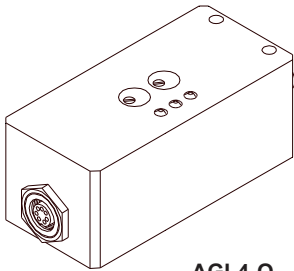

AGL4-Q
AGL4-Qinv
AGL4-Qinv-200ms

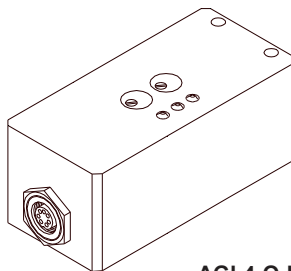

AGL4-Q-HS-500kHz-24V_LED
AGL4-Qinv-HS-500kHz-24V_LED

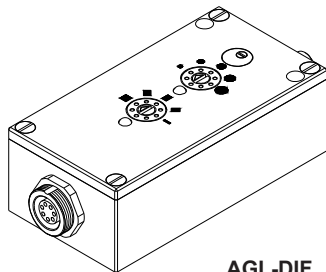

AGL-DIF

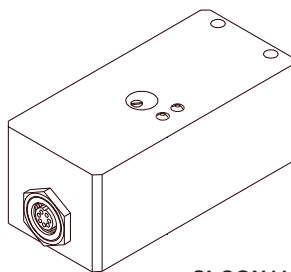

SI-CON11-0/20
SI-CON11-0/20-5V
SI-CON11-0/20-IC
SI-CON11-4/20
SI-CON11-4/20-IC
SI-CON11-5/25
SI-CON11-5/25-IC

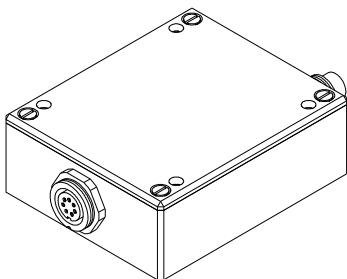

SI-CON8
(incl. Windows® PC software
SI-CON8-Scope)

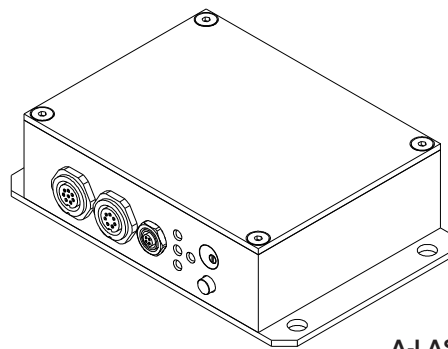

A-LAS-CON1
(incl. Windows® PC software
A-LAS-CON1-Scope)

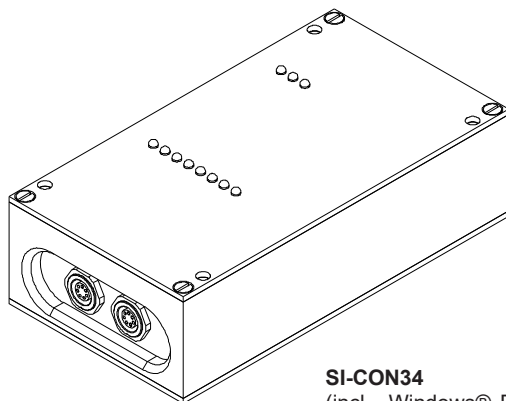

SI-CON34
(incl. Windows® PC software
SCOPE34)