

D-LAS Series

► D-LAS90-...

- Collimated laser beam (<0.4 mW, 670 nm), **laser class 1**
- Various apertures available: Round apertures up to Ø 2 mm or rectangular apertures up to 4 mm x 2 mm
- Interference filter
- Max. working range typ. 100 m (depends on aperture used)
- Min. detectable object typ. 0.1 mm
- Switching frequency 1 kHz
- Optics cover made of glass
- Sturdy metal housing

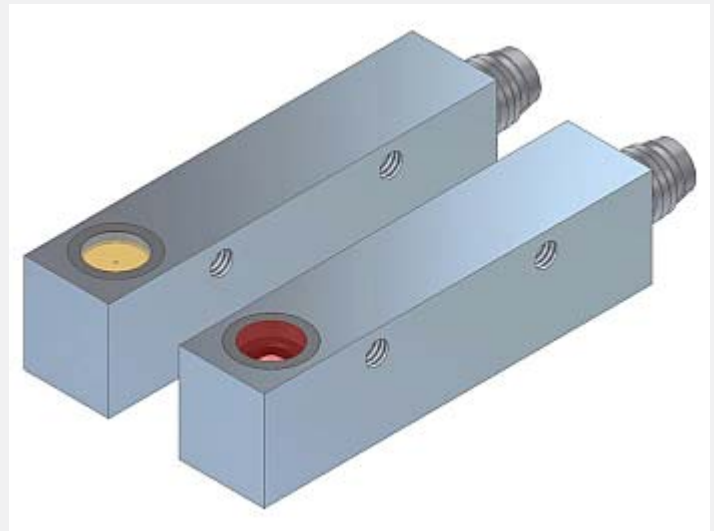

Design

Product name:

Transmitter: D-LAS90-(aperture)*-T

**Receiver: D-LAS90-Q-(aperture)*-R
D-LAS90-Qinv-(aperture)*-R**

- Q = Switching output:
nnp dark-switching (nnp n.o.)/
pnp bright-switching (pnp n.c.)
- Qinv = Switching output:
pnp dark-switching (pnp n.o.)/
nnp bright-switching (nnp n.c.)

*Available apertures:

Round apertures Ø (mm):	Rectangular apertures AxB (mm):	or	AxB (mm):
d0.15	0.3x0.5		0.5x0.3
d0.2	0.3x1		1x0.3
d0.3	0.3x1.5		1.5x0.3
d0.5	0.3x3		3x0.3
d0.7	0.5x1		1x0.5
d1.0	0.5x4		4x0.5
d2.0	0.75x2		2x0.75
	0.75x3		3x0.75
	2x4 (= no aperture)		4x2 (= no aperture)

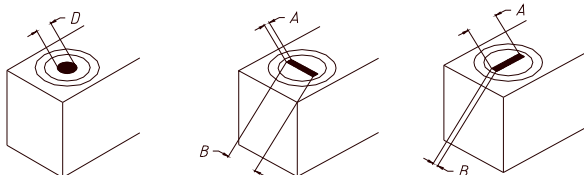
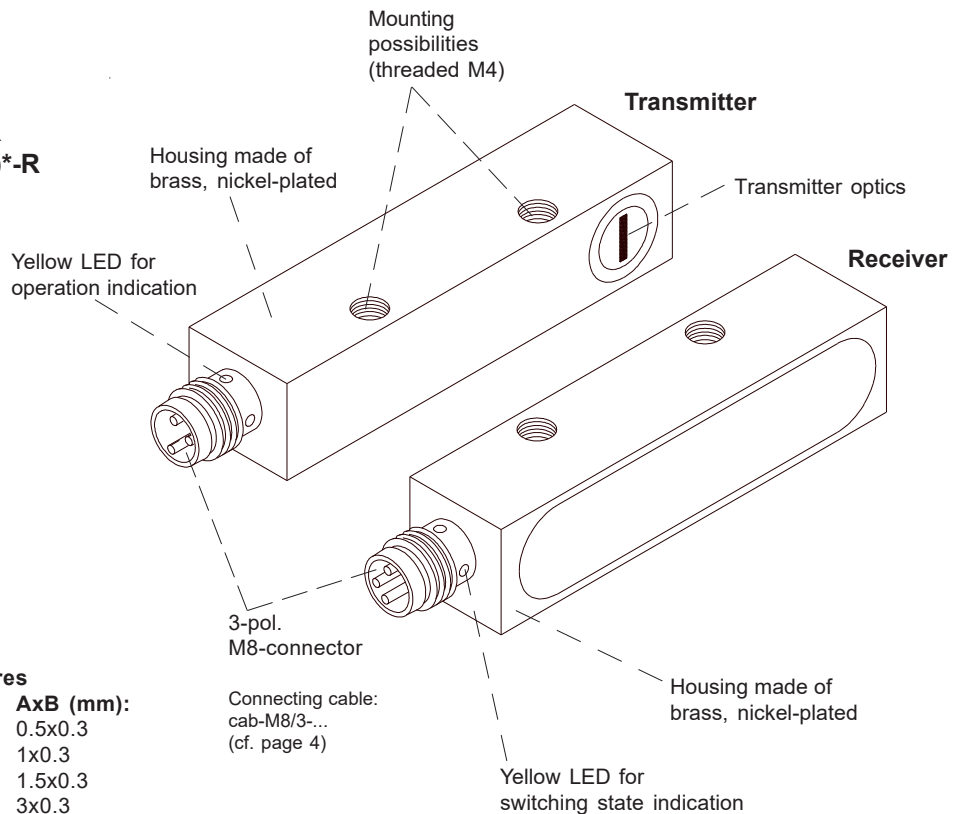



Technical Data

Type	D-LAS90
Laser	Solid state laser, 670 nm, AC operation, <0.4 mW opt. power, laser class 1 acc. to DIN EN 60825-1. The use of these laser transmitters therefore requires no additional protective measures.
Max. range	100 m (depends on the aperture used) e.g. for D-LAS90-4x2-... (where no aperture is used) the max. range is 100m (spot size 300 mm x 100mm)
Min. detectable object	typ. 1% of aperture size
Reproducibility	typ. 1% of aperture size
Optical filter	Interference filter
Voltage supply	+24VDC (± 10%), protected against polarity reversal, overload protected
Alternating current/ direct current supply	AC operation (100 kHz)
Ambient light	up to 5000 Lux (depends on the aperture used)
Current consumption	Transmitter: typ. 60 mA Receiver: typ. 30 mA
Max. size of aperture	Round aperture: max. Ø 2.0 mm, rectangular aperture: max. 4 mm x 0.5 mm respectively max. 4 mm x 2 mm (no aperture is used, i.e. the transmitter optics itself is working as an aperture)
Current control input I-CONTROL	0V ... +5V: Laser power decreases linearly with increasing voltage +5V ... +24V: Laser OFF
Type of protection	IP67
Operating temperature range	-20°C ... +50°C
Storage temperature range	-20°C ... +85°C
Housing material	Brass, nickel-plated
Housing dimensions	Transmitter respectively receiver: approx. 55 mm x 14 mm x 12 mm
Connector type	M8, 3-pole
LED indication	Transmitter: LED yellow for operation indication (integrated in M8 connector) Receiver: LED yellow for switching state indication (integrated in M8 connector)
Max. switching current	100 mA, short-circuit-proof
EMC test acc. to	DIN EN 60947-5-2 
Switching frequency	typ. 1 kHz



Laser Information

The laser transmitters of D-LAS series comply with laser class 1 according to EN 60825-1. Under reasonably foreseeable conditions a class 1 laser is safe. The reasonably foreseeable conditions are kept during specified normal operation. The use of these laser transmitters therefore requires no additional protective measures.

The laser transmitters of D-LAS series are supplied with a laser information label „CLASS 1 Laser Product“.

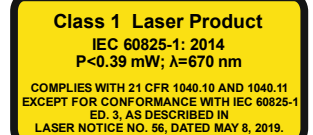

Dimensions

D-LAS90-...-T
Transmitter with
rectangular aperture

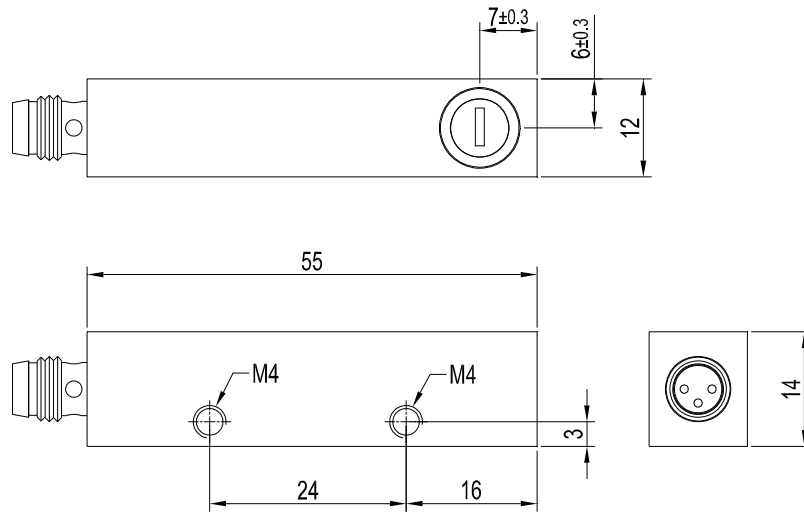

D-LAS90-...-T
Transmitter with
round aperture

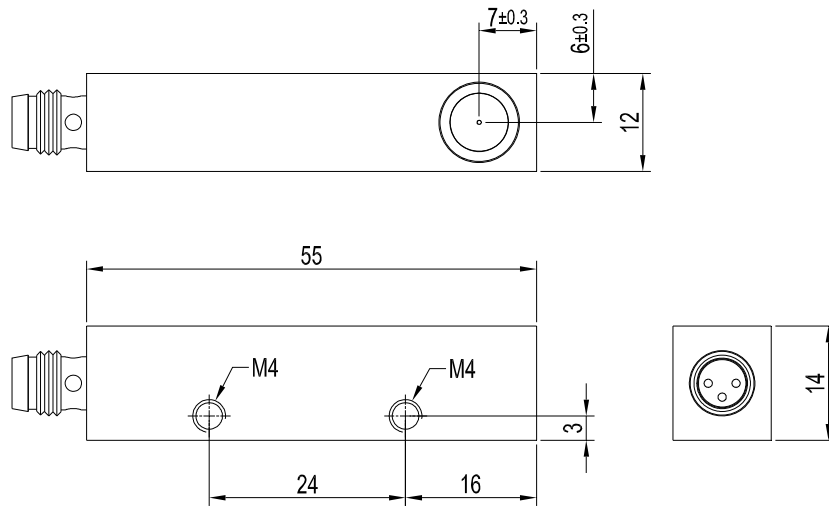

D-LAS90-...-R
Receiver

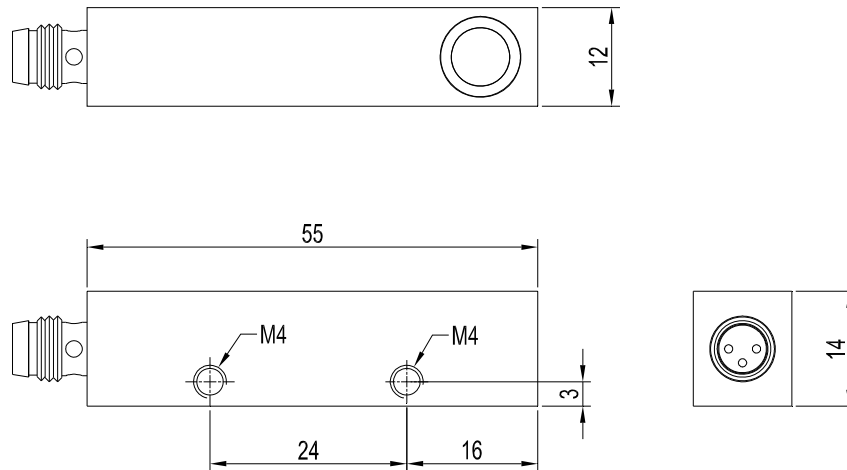

(All dimensions in mm)

Connector Assignment

Receiver

(3-pole M8-connector)

Type Q (npn dark-switching / pnp bright-switching):

Pin No.:	Color:	Assignment:
1	brn	+24VDC (± 10%)
3	blu	GND (0V)
4	blk	OUTPUT

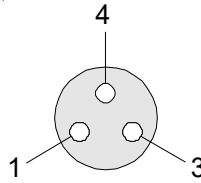

Transmitter

(3-pole M8-connector)

Pin No.:	Color:	Assignment:
1	brn	+24VDC (± 10%)
3	blu	GND (0V)
4	blk	I-CONTROL (0...+24V)

Type Qinv (pnp dark-switching / npn bright-switching):

Pin No.:	Color:	Assignment:
1	brn	+24VDC (± 10%)
3	blu	GND (0V)
4	blk	OUTPUT INV

Connecting Cables

Available connecting cables:

cab-M8/3-g-2m	Length: 2m	Outer jacket: PUR	
cab-M8/3-g-5m	Length: 5m	Outer jacket: PUR	
cab-M8/3-w-2m	Length: 2m	Outer jacket: PUR	angle type
cab-M8/3-w-5m	Length: 5m	Outer jacket: PUR	angle type
cab-M8/3-w-npn-2m	Length: 2m	Outer jacket: PUR	angle type, LED
cab-M8/3-w-npn-5m	Length: 5m	Outer jacket: PUR	angle type, LED
cab-M8/3-w-pnp-2m	Length: 2m	Outer jacket: PUR	angle type, LED
cab-M8/3-w-pnp-5m	Length: 5m	Outer jacket: PUR	angle type, LED

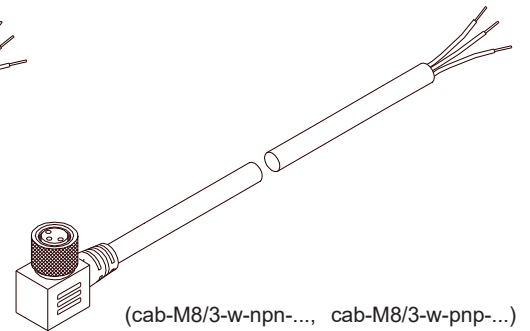
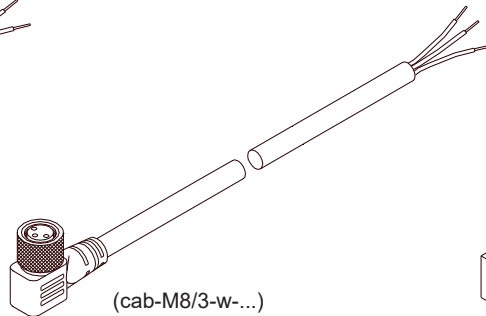
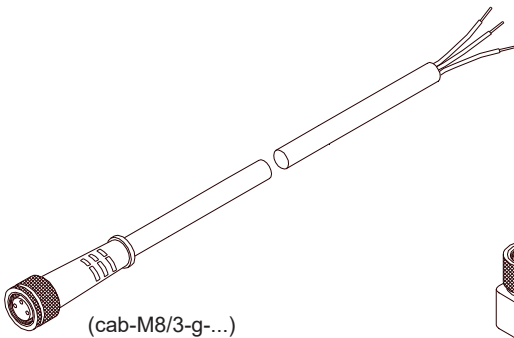
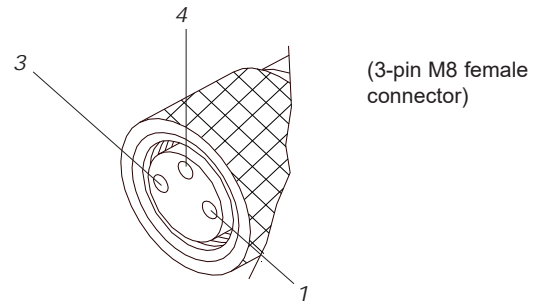

Mounting

Mounting flanges (please order separately):

FL-90 (Flat flange: adjusting possibility horizontally)

WFL-90 (Angle flange: adjusting possibility vertically)

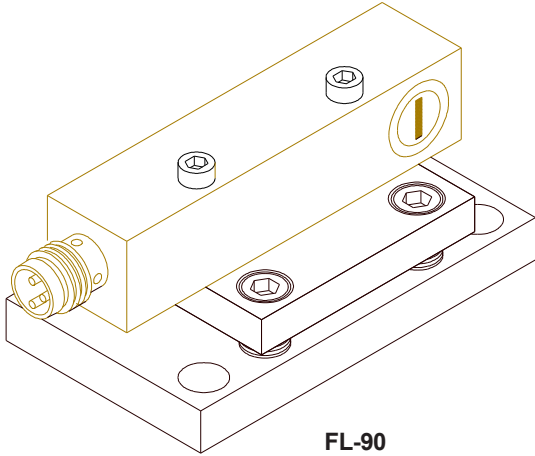

FL-90
(Flat flange)

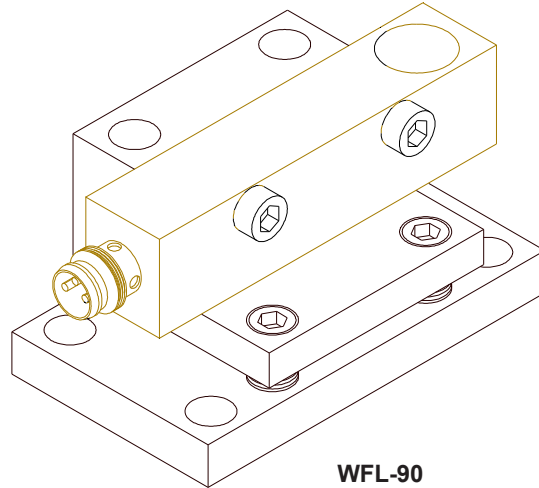

WFL-90
(Angle flange)

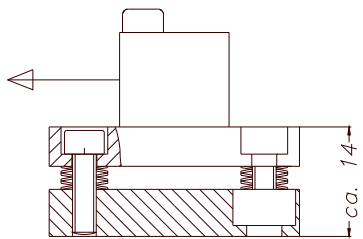

Senkung DIN 74Km4

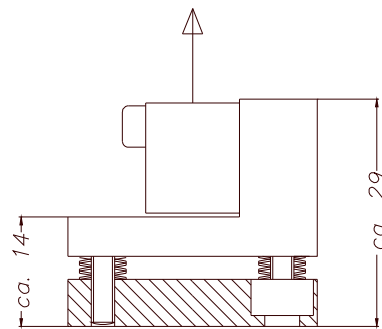

Senkung DIN 74Km4

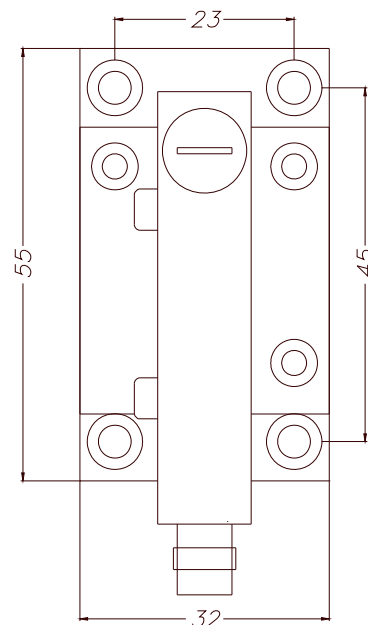
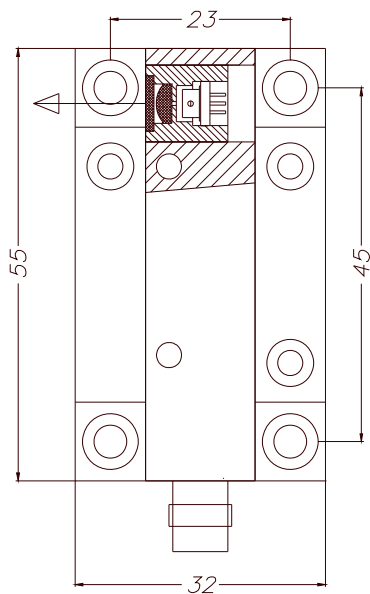

(All dimensions in mm)



Product Line

Type summary D-LAS Series

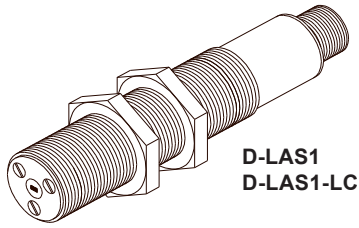

D-LAS1
D-LAS1-LC

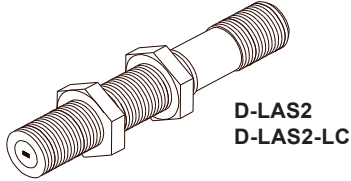

D-LAS2
D-LAS2-LC

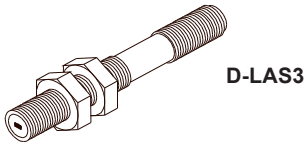

D-LAS3

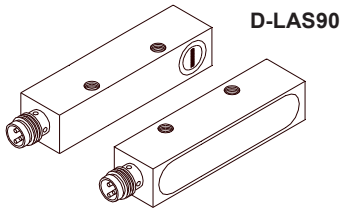

D-LAS90

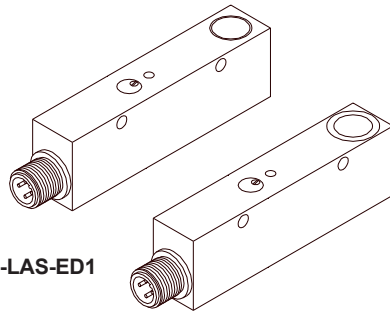

D-LAS-ED1

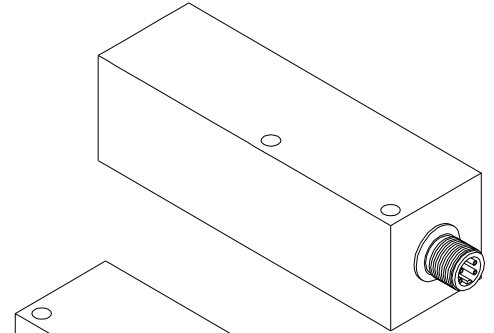

D-LAS-34

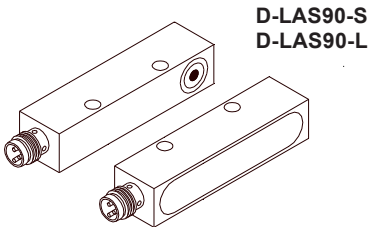

D-LAS90-S
D-LAS90-L

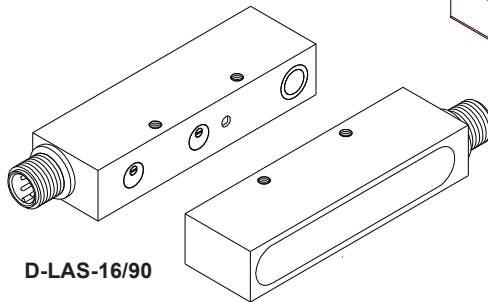

D-LAS-16/90

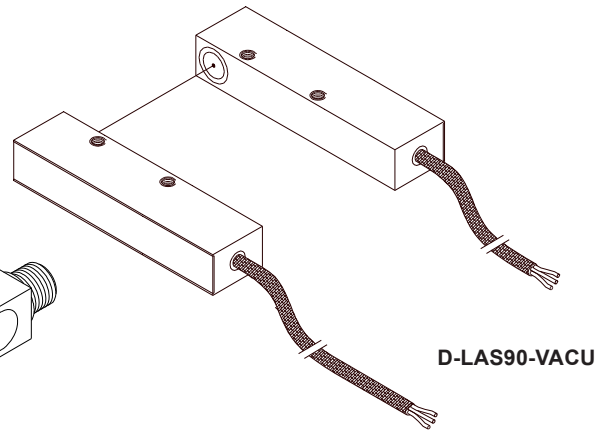

D-LAS90-VACU

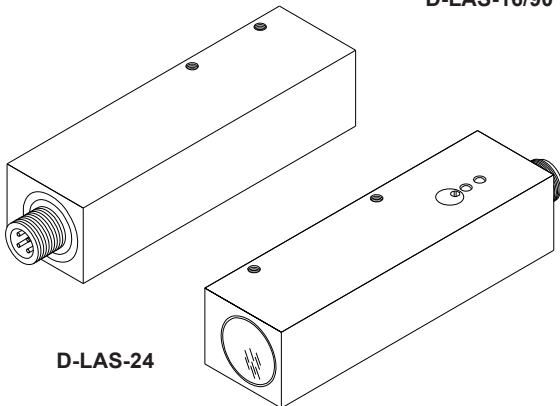

D-LAS-24

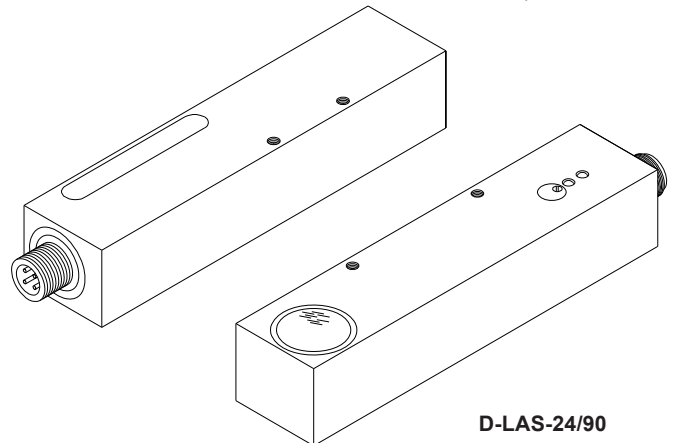

D-LAS-24/90